



Power line chokes

Ring core choke with iron powder core

Series/Type:	R 18
Ordering code:	B82622S0173L030
Date:	2016-05-11
Version:	01

© EPCOS AG 2016. Reproduction, publication and dissemination of this publication, enclosures hereto and the information contained therein without EPCOS' prior express consent is prohibited.

EPCOS AG is a TDK Group Company.

Rated current: 30 A / +85 °C

Rated inductance: 2.1 μ H

Construction

- Ring core choke with iron powder core
- Sector winding
- Baseplate
- Core, pins and baseplate glued



Features

- Baseplate flame retardant as per UL 94 V-0
- Enameled wire in accordance to EN 60317-13
- RoHS-compatible

Applications

- EMC choke

Terminals

- Ends of winding wire
- Pins hot dip tinned with Sn99Cu

Marking

- Manufacturer, ordering code and date code (YYWWD/X)

Delivery mode and packing units

- Blister tray
- 72 pcs per tray

Dimensional drawing

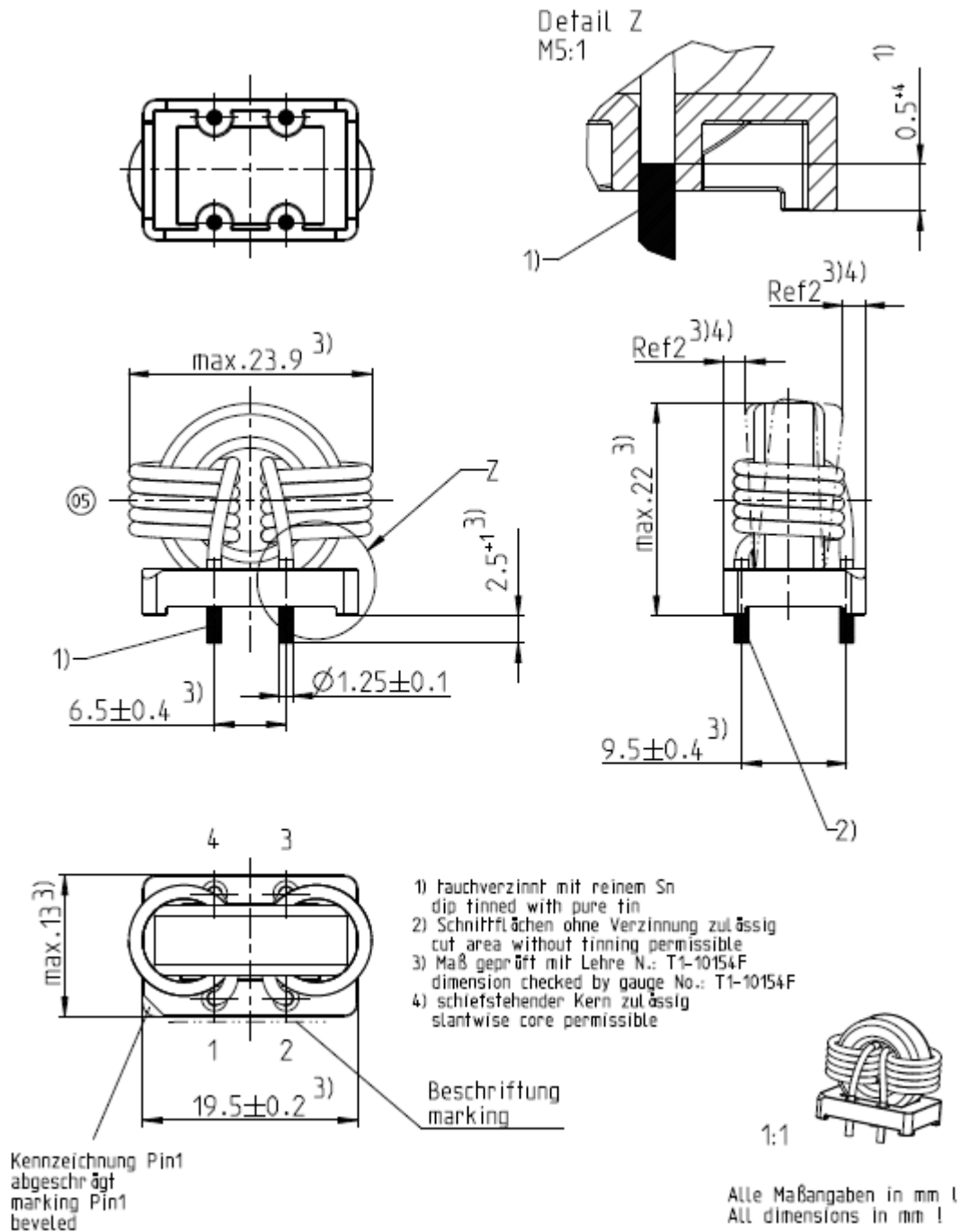

Technical data and measuring conditions

Rated inductance L_R	2.1 μH Measured at 100 kHz, 0.1 mA, +20 °C (both windings parallel connected)
Rated temperature T_R	+85 °C
Rated current I_R	30 A Referred to rated temperature T_R
Inductance tolerance	$\pm 15\%$ at +20 °C
Inductance $L @ 70 \text{ A}$	0.5 μH (both windings parallel connected)
DC resistance R_{typ}	2.45 m Ω Measured at +20 °C, typical value, specified per winding, end of baseplate.
DC resistance R_{max}	2.80 m Ω Measured at +20 °C, max. value, specified per winding, end of baseplate.
Test voltage V_{test}	500 V AC, 2 s (line/line)
Operating temperature range	-40 °C ... +150 °C
Weight	Approx. 13 g

Cautions and warnings

- Additional information is contained in our data books, which are also available on the internet. Particular attention should be paid to the derating curves given there. The soldering conditions given there should also be observed. **Temperatures** quoted in relation to wave soldering **refer to the pin, not to the housing**.
- If the components are to be washed varnished, it is necessary to check whether any washing varnish agent that is used has a negative effect on the wire insulation, any plastics that are used, or on glued joints. In particular, it is possible for washing varnish agent residues to have a negative effect in the long-term on wire insulation. Washing processes may damage the product due to the possible static or cyclic mechanical loads (e.g. ultrasonic cleaning). They may cause cracks to develop on the product and its parts, which might lead to reduced reliability or lifetime.
- The following points must be observed if the components are potted in customer applications:
 - Many potted materials shrink as they harden. They therefore exert a pressure on the plastic housing or core. This pressure can have a deleterious effect on electrical properties and, in extreme cases, can damage the core or plastic housing mechanically;
 - It is necessary to check whether the potting material used attacks or destroys the wire insulation, plastics or glue;
 - The effect of the potting material can change the high frequency behaviour of the components.
- Ferrites are sensitive to direct impact. This can cause the core material to flake, or lead to breakage of the core.

Even for customer specific products, conclusive validation of the components in the circuit can only be carried out by the customer.

Display of ordering codes for EPCOS products

The ordering code for one and the same EPCOS product can be represented differently in data sheets, data books, other publications, on the EPCOS website, or in order-related documents such as shipping notes, order confirmations and product labels. **The varying representations of the ordering codes are due to different processes employed and do not affect the specifications of the respective products.** Detailed information can be found on the Internet under www.epcos.com/orderingcodes

Important notes

The following applies to all products named in this publication:

1. Some parts of this publication contain **statements about the suitability of our products for certain areas of application**. These statements are based on our knowledge of typical requirements that are often placed on our products in the areas of application concerned. We nevertheless expressly point out **that such statements cannot be regarded as binding statements about the suitability of our products for a particular customer application**. As a rule, EPCOS is either unfamiliar with individual customer applications or less familiar with them than the customers themselves. For these reasons, it is always ultimately incumbent on the customer to check and decide whether an EPCOS product with the properties described in the product specification is suitable for use in a particular customer application.
2. We also point out that **in individual cases, a malfunction of electronic components or failure before the end of their usual service life cannot be completely ruled out in the current state of the art, even if they are operated as specified**. In customer applications requiring a very high level of operational safety and especially in customer applications in which the malfunction or failure of an electronic component could endanger human life or health (e.g. in accident prevention or life-saving systems), it must therefore be ensured by means of suitable design of the customer application or other action taken by the customer (e.g. installation of protective circuitry or redundancy) that no injury or damage is sustained by third parties in the event of malfunction or failure of an electronic component.
3. **The warnings, cautions and product-specific notes must be observed.**
4. In order to satisfy certain technical requirements, **some of the products described in this publication may contain substances subject to restrictions in certain jurisdictions (e.g. because they are classed as hazardous)**. Useful information on this will be found in our Material Data Sheets on the Internet (www.epcos.com/material). Should you have any more detailed questions, please contact our sales offices.
5. We constantly strive to improve our products. Consequently, **the products described in this publication may change from time to time**. The same is true of the corresponding product specifications. Please check therefore to what extent product descriptions and specifications contained in this publication are still applicable before or when you place an order. We also **reserve the right to discontinue production and delivery of products**. Consequently, we cannot guarantee that all products named in this publication will always be available. The aforementioned does not apply in the case of individual agreements deviating from the foregoing for customer-specific products.
6. Unless otherwise agreed in individual contracts, **all orders are subject to the current version of the "General Terms of Delivery for Products and Services in the Electrical Industry" published by the German Electrical and Electronics Industry Association (ZVEI)**.
7. The trade names EPCOS, Alu-X, CeraDiode, CeraLink, CeraPad, CeraPlas, CSMP, CSSP, CTVS, DeltaCap, DigiSiMic, DSSP, ExoCore, FilterCap, FormFit, LeaXield, MiniBlue, MiniCell, MKD, MKK, MotorCap, PCC, PhaseCap, PhaseCube, PhaseMod, PhiCap, PQSine, SIFERRIT, SIFI, SIKOREL, SilverCap, SIMDAD, SiMic, SIMID, SineFormer, SIOV, SIP5D, SIP5K, TFAP, ThermoFuse, WindCap are **trademarks registered or pending** in Europe and in other countries. Further information will be found on the Internet at www.epcos.com/trademarks.