

## Filters for Power Lines

Filter Cabinets  
(300 to 1600 A)

**Series/Type:**      **B84299G**

Date: January 2004

© EPCOS AG 2015. Reproduction, publication and dissemination of this publication, enclosures hereto and the information contained therein without EPCOS' prior express consent is prohibited.

EPCOS AG is a TDK Group Company.

**Filter cabinets (300 to 1600 A)**
**Features**

- General-purpose use through design with separate lines without intercoupling
- Use of single chokes.  
Thus the insertion loss values are not reduced under all operating current conditions and not when operated with artificial mains networks (AMN) or other equipment with high leakage currents
- Cable connection in filter eliminating extra mechanical effort
- Insertion loss to CISPR 17
- Stopband attenuation to 40 GHz

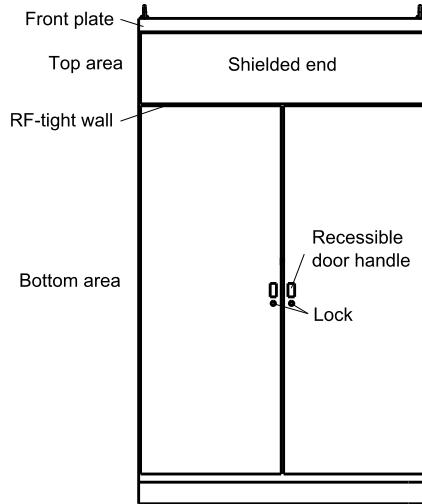

SGR0183-S-E

**Design**

The filter cabinet consists of 2 areas.

The bottom area holds the low-frequency filter circuitry consisting of capacitors and chokes.

The top area is RF-tight. This is where the cables leading to the shielded room are connected.

The 2 areas of the cabinet are joined by an RF-tight wall, integrated into which there are coaxial feed-through capacitors. The wall is of high-grade Cr-Ni steel material, ensuring constant and non-corroding contact with the feed-through capacitors even in an unfavorable environment.

**Access and connection**

The bottom area is accessible through two doors, each fitted with a recessible handle and lock. The top area has a specially designed lid with a dual seal that is bolted RF-tight to the cabinet.

In each area there are copper terminal rails for cable connection. Modified cable inlets and outlets are available on inquiry.

**Electrical design**

Filtering is separate for each line. This maintains the specified attenuation even in the presence of leakage current and on full load.

### Capacitor configuration

The capacitors are able to handle peak current far in excess of the rms current. In this way they can discharge high-energy transients without suffering damage.

The capacitors are self-healing and come with integrated overpressure disconnection. Consequently a capacitor will not burst under inadmissible overload or at the end of its service life.

### RF-tight cable routing from top cabinet area to shielding wall

RF-tight cable routing uses flexible connector fittings with an inner diameter of 80 mm. The connector fittings must be ordered separately.

There are matching openings for the connector fittings on the rear of the cabinet. Unused openings can be sealed with special cover flange plates.

Refer to the chapter on installation accessories for connector fittings and cover flange plates.

### Installation

On the front and rear of its base, the filter cabinet has a plate that can be unscrewed. After removing these plates, a cabinet can be simply moved with a forklift truck for example. There is a ring at each corner on the top for use of a crane.

For enhanced protection against shock, there are openings in the bottom so that the cabinet can be bolted to the floor.

### Protective measures (grounding)

The high capacitances between the lines and ground require special protective measures. If there are no product-specific requirements, protection with a secondary ground wire (cross section min. 10 mm<sup>2</sup>) in accordance with EN 50178 is necessary. For this purpose the filter case have connecting bolts at each end.

Resistors are incorporated in the filter to discharge capacitors after turn-off.

### EMP protection

For overvoltage protection, the cabinet can be fitted with block varistors (model SIOV B80K...). The advantage of varistors is the absence of follow-up current once the overvoltage has decayed. These block varistors are also notable for their high discharge capacity (max. 100000 A for an 8/20  $\mu$ s curve per line).

Circuit diagramm

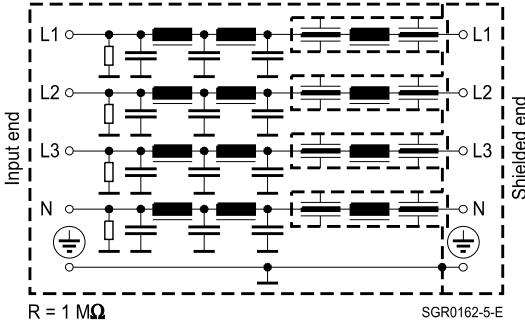

Insertion loss  $\alpha_e$  (typical values at Z = 50 Ω)

Measurement circuit

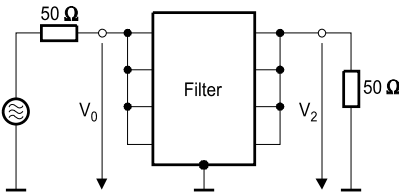

$$\alpha_e = 20 \lg \frac{V_0}{2 \cdot V_2} \text{ [dB]}$$

SGR0163-D-E

Asymmetrical measurement circuit to MIL-STD-220A

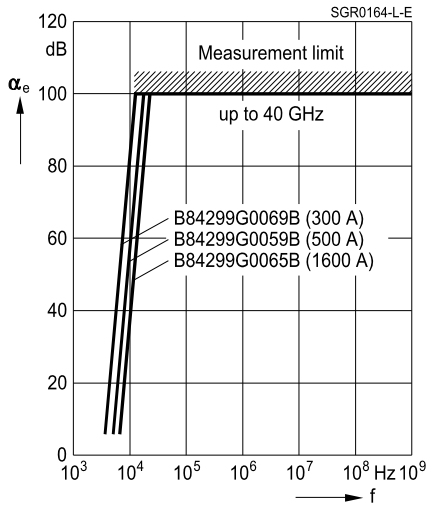

**Filters for power lines**
**B84299G**
**Filter cabinets (300 to 1600 A)**
**General technical data**

Rated voltage	$V_R$	440	V	Line/line
		250	V	Line/case
Number of lines		4		
Rated frequency	$f_R$	50/60	Hz	
Rated current	$I_R$	See characteristics		Referred to +40 °C ambient temperature
Maximum admissible overcurrent	$I_{over}$	75 · $I_R$ for 50 ms 10 · $I_R$ for 1 s 2 · $I_R$ for 1 min 1.4 · $I_R$ for 15 min		
Test voltage	$V_{test}$	1200 VDC, 2 s		Line/line
		1200 VDC, 2 s		Line/case
Voltage drop/phase	$\Delta V$	<1	%	Of $V_R$ at 50 Hz and $I_R$
Maximum DC resistance	$R_{max}$	See characteristics		Per line
Permissible ambient temperature	$T_A$	-25/+40	°C	
Climatic category (EN 60068-1)		25/085/56		-25 °C/+85 °C/56 days damp heat test

**Characteristics and ordering codes**

$I_R$ A	$R_{max}$ mΩ	Dimensional drawing	Approx. weight kg	Ordering code <sup>1)</sup>
300	< 1	1	400	B84299G0069B...
500	< 0.5	1	450	B84299G0059B...
1600	< 0.03	2	800	B84299G0065B...

1) ... = Ordering code will be completed by the producer.

Dimensional drawings

Dimensional drawing 1

4 x 300 A / 4 x 500 A

Top view

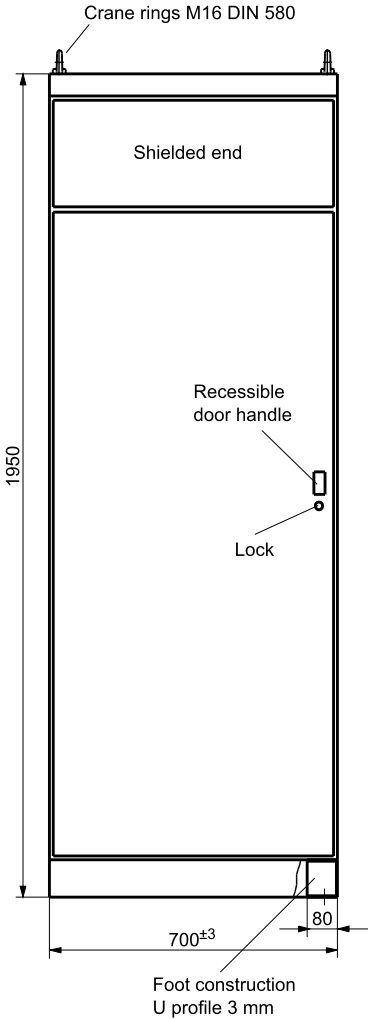

Rear view

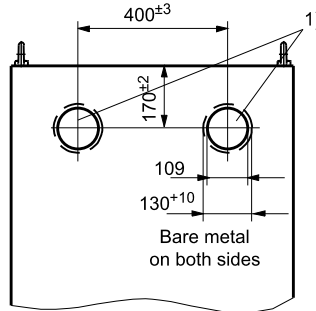

1) Connecting to shielding wall  
by flexible connector fittings  
(must be ordered separately)

Bottom view

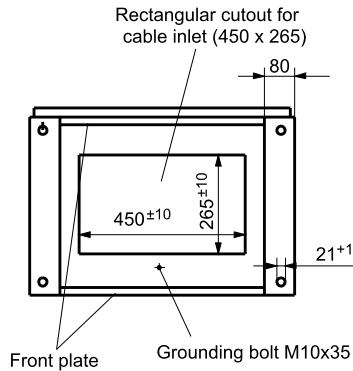

SGR0327-U-E

Paint color: RAL 7035 (light gray, semigloss)

**Dimensional drawing 2**

**4 x 1600 A**

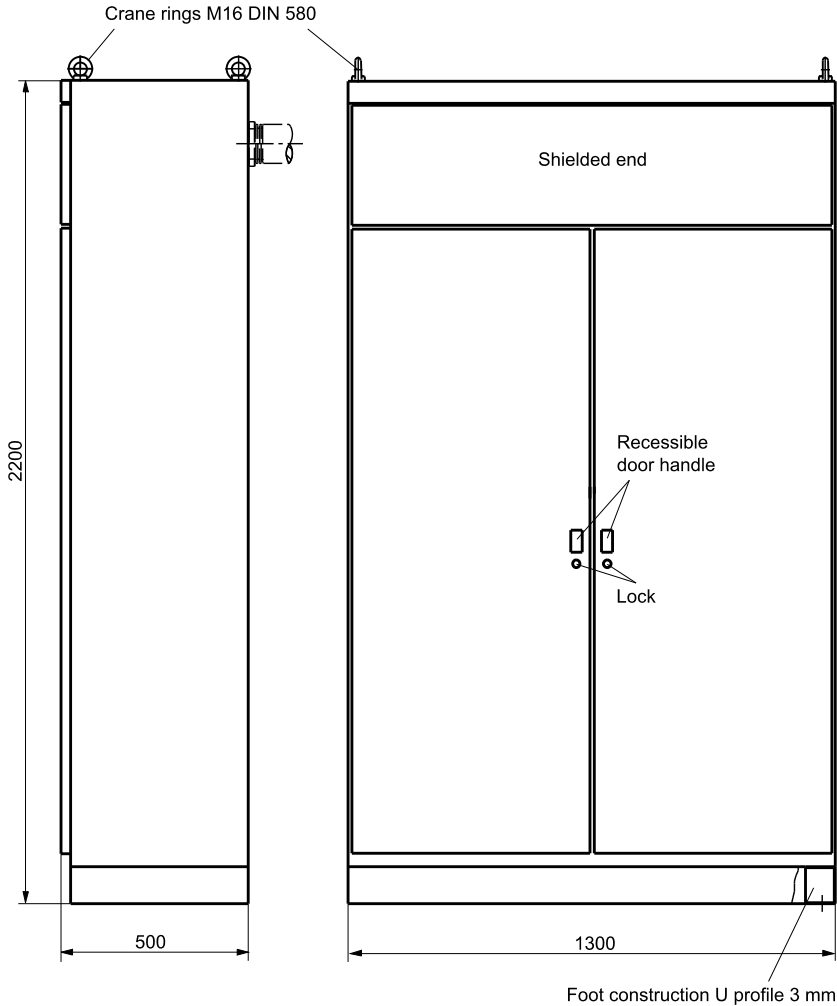

SGR0168-J-E

Paint color: RAL 7035 (light gray, semigloss)

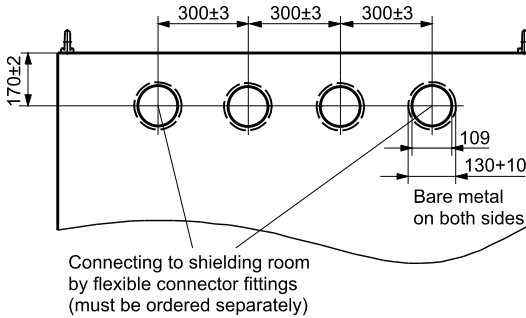
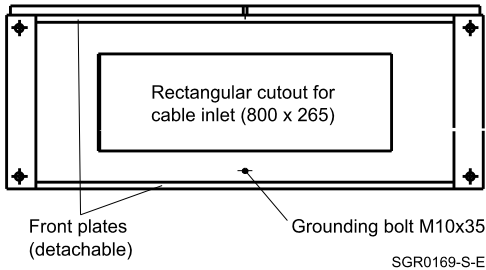
**Dimensional drawing 2 (continued)**
**Rear view**

**Bottom view**

Inquire for modified cable inlets and outlets.

Must be ordered separately:	Ordering code
Connector fitting (inner diameter = 80 mm)	B84298A0046L***
Cover flange for RF-tight sealing of unused connector openings	B84298M0080C001

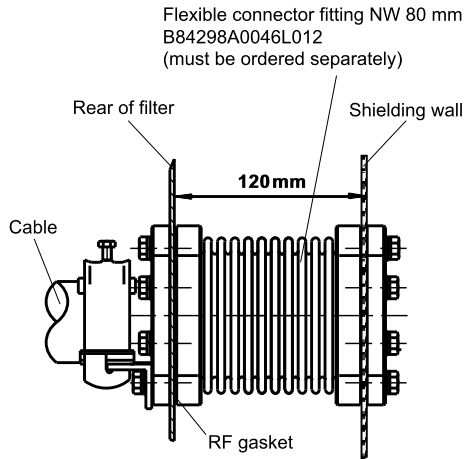
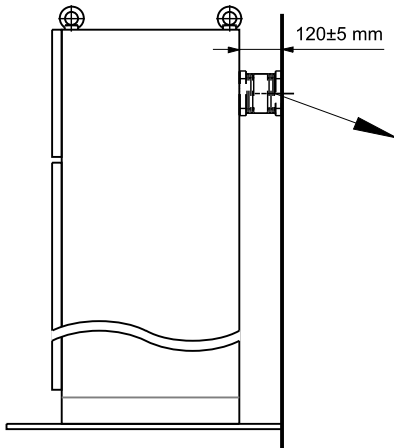

**Example of RF-tight installation with connector fitting**



SGR0170-V-E

## Important notes

The following applies to all products named in this publication:

1. Some parts of this publication contain **statements about the suitability of our products for certain areas of application**. These statements are based on our knowledge of typical requirements that are often placed on our products in the areas of application concerned. We nevertheless expressly point out **that such statements cannot be regarded as binding statements about the suitability of our products for a particular customer application**. As a rule we are either unfamiliar with individual customer applications or less familiar with them than the customers themselves. For these reasons, it is always ultimately incumbent on the customer to check and decide whether a product with the properties described in the product specification is suitable for use in a particular customer application.
2. We also point out that **in individual cases, a malfunction of electronic components or failure before the end of their usual service life cannot be completely ruled out in the current state of the art, even if they are operated as specified**. In customer applications requiring a very high level of operational safety and especially in customer applications in which the malfunction or failure of an electronic component could endanger human life or health (e.g. in accident prevention or life-saving systems), it must therefore be ensured by means of suitable design of the customer application or other action taken by the customer (e.g. installation of protective circuitry or redundancy) that no injury or damage is sustained by third parties in the event of malfunction or failure of an electronic component.
3. **The warnings, cautions and product-specific notes must be observed.**
4. In order to satisfy certain technical requirements, **some of the products described in this publication may contain substances subject to restrictions in certain jurisdictions (e.g. because they are classed as hazardous)**. Useful information on this will be found in our Material Data Sheets on the Internet ([www.tdk-electronics.tdk.com/material](http://www.tdk-electronics.tdk.com/material)). Should you have any more detailed questions, please contact our sales offices.
5. We constantly strive to improve our products. Consequently, **the products described in this publication may change from time to time**. The same is true of the corresponding product specifications. Please check therefore to what extent product descriptions and specifications contained in this publication are still applicable before or when you place an order.  
  
We also **reserve the right to discontinue production and delivery of products**. Consequently, we cannot guarantee that all products named in this publication will always be available. The aforementioned does not apply in the case of individual agreements deviating from the foregoing for customer-specific products.
6. Unless otherwise agreed in individual contracts, **all orders are subject to our General Terms and Conditions of Supply**.
7. **Our manufacturing sites serving the automotive business apply the IATF 16949 standard**. The IATF certifications confirm our compliance with requirements regarding the quality management system in the automotive industry. Referring to customer requirements and customer specific requirements ("CSR") TDK always has and will continue to have the policy of respecting individual agreements. Even if IATF 16949 may appear to support the acceptance of unilateral requirements, we hereby like to emphasize that **only requirements mutually agreed upon can and will be implemented in our Quality Management System**. For clarification purposes we like to point out that obligations from IATF 16949 shall only become legally binding if individually agreed upon.
8. The trade names EPCOS, CeraCharge, CeraDiode, CeraLink, CeraPad, CeraPlas, CSMP, CTVS, DeltaCap, DigiSiMic, ExoCore, FilterCap, FormFit, LeaXield, MiniBlue, MiniCell, MKD, MKK, MotorCap, PCC, PhaseCap, PhaseCube, PhaseMod, PhiCap, PowerHap, PQSine, PQvar, SIFERRIT, SIFI, SIKOREL, SilverCap, SIMDAD, SiMic, SIMID, SineFormer, SIOV, ThermoFuse, WindCap are **trademarks registered or pending** in Europe and in other countries. Further information will be found on the Internet at [www.tdk-electronics.tdk.com/trademarks](http://www.tdk-electronics.tdk.com/trademarks).