



Switching spark gap

SSG with lead wires

Series/Type: SSG3CX-1
Ordering code: B88069X5903****
Date: 2019-07-19
Version: 01

Features

- Extremely long life time
- Stable performance over life
- Insensitive performance against variations in temperature
- Low switching losses
- Very short breakdown time
- High reliability by robust design
- RoHS compatible

Applications

- Ignition of HID lamps for video projection

Electrical specifications

Nominal breakdown voltage V_n	3000	V
Initial values ²⁾		
Static breakdown voltage V_s ¹⁾		
First ignition value $V_{s, fte}$ after 24 hours in darkness	≤ 3900	V
Following ignition values $V_{s, fiv}$	2550 ... 3540	V
Electrical life time ³⁾		
Breakdown voltage V_b		
First ignition value $V_{B, FTE}$ after 24 hours in darkness	≤ 4200	V
Following ignition values $V_{B, FIV}$	2400 ... 3600	V
Switching operations at 0 °C ... +100 °C	1000 000	Ignitions
Test circuit parameters		
Open circuit voltage V_o	4200	V
Loading resistance R	4000	k Ω
Discharge capacitance C	1.5	nF
Inductance L	7.5	μ H
Discharge peak current I_p	50	A
General technical data		
Insulation resistance at 100 V	> 100	M Ω
Early ignition values below 2400 V	≤ 1	%
Breakdown time	≤ 50	ns
Maximum switching frequency	400	Hz
Weight	~ 2	g
Marking, red positive	EPCOS 3000 YY O	
	3000 - Nominal voltage	
	YY - Year of production	
	O - Non radioactive	

¹⁾ At delivery AQL 0,65 level II, DIN ISO 2859

²⁾ Page 2, Fig. 1 and 2

³⁾ Page 2, Fig. 3 and 4

Test circuits

Fig. 1: QC- test circuit (100% outgoing inspection)

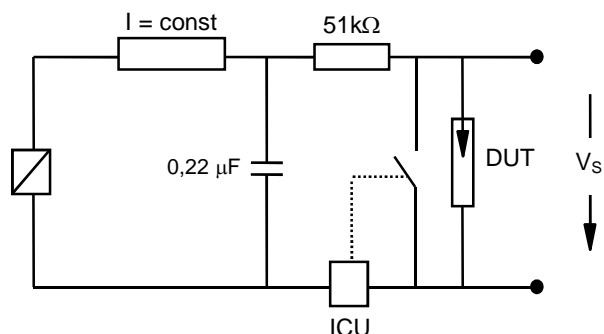

DUT device under test
 ICU ignition control unit (sensitivity 10 ... 30 μA)
 Discharge current 10 ... 20 mA

Fig. 2: Explanation of measurands

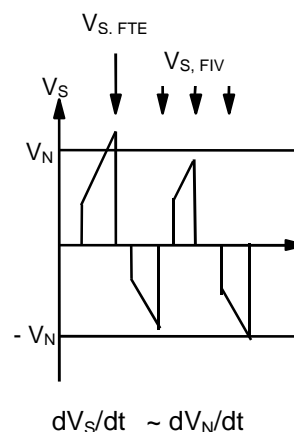

Fig. 3: QC- test circuit (sampling inspection at 25 °C)

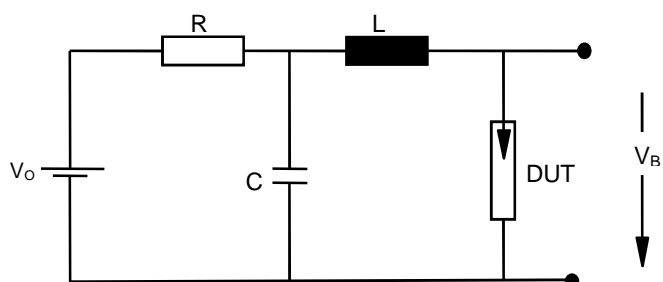
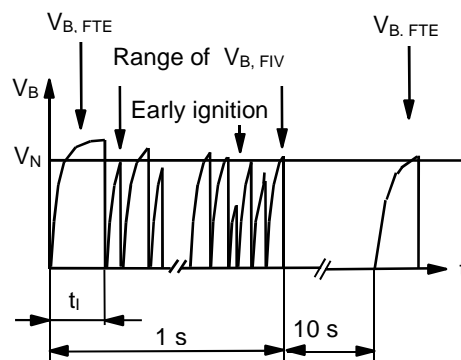
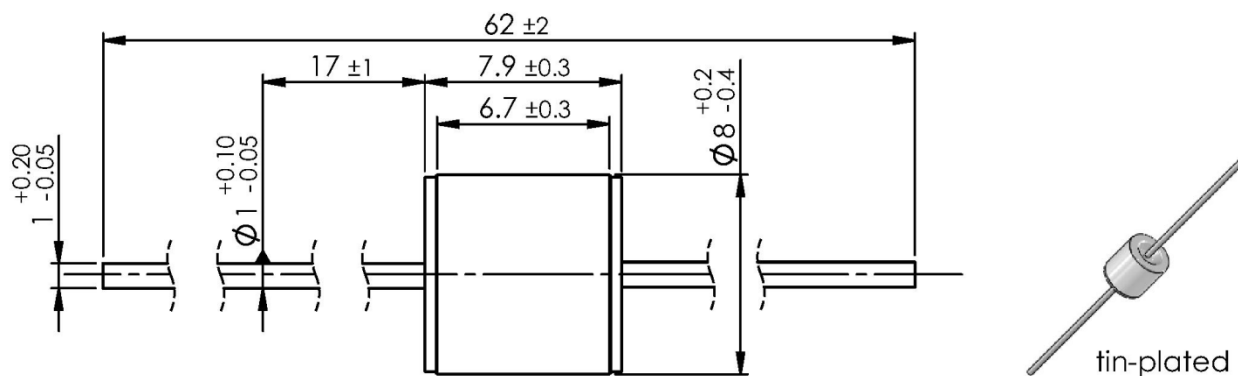
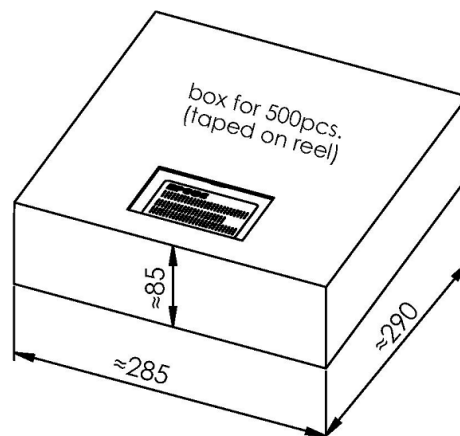
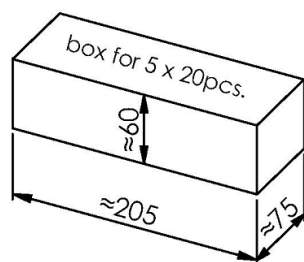
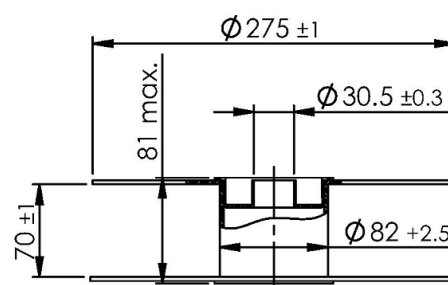
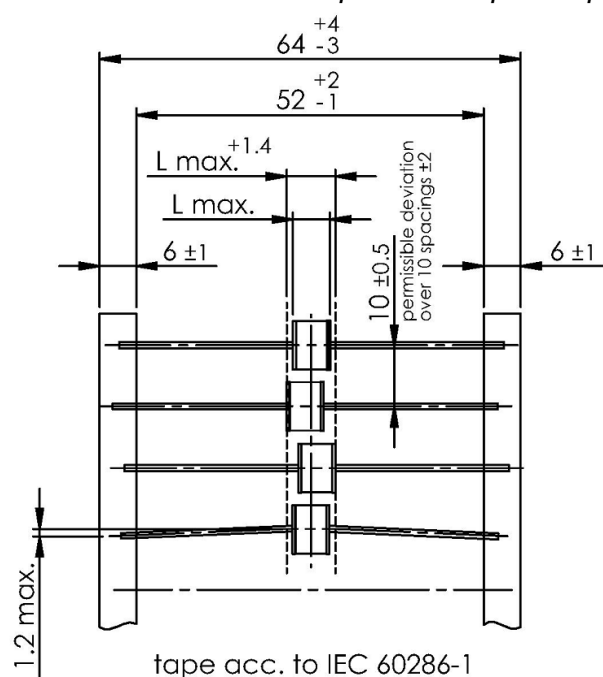

Fig. 4: Explanation of measurands



Dimensional drawing in mm

Ordering code and packing advice
B88069X5903S102 = 100 pcs. on 5 taped stripes
B88069X5903T502 = 500 pcs. on tape and reel

Soldering parameter

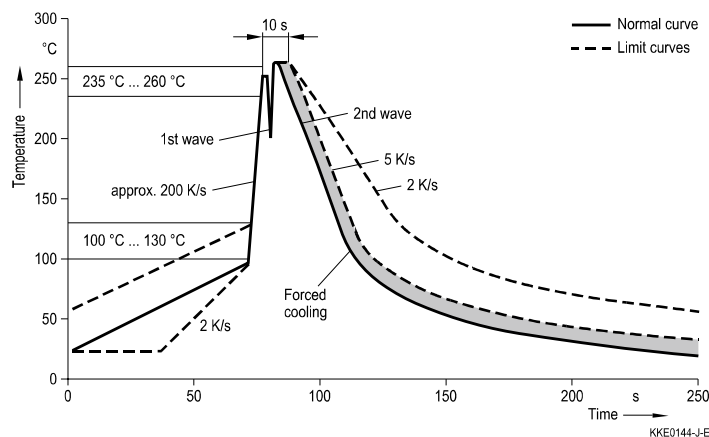
Wave soldering



Wave profile features	Pb-free assembly
Solder	Sn 95.5 / Ag 3.8 / Cu 0.7
Solder bath temperature	263 (±3) °C
Dwell time	< 3 s

Soldering profile applied to a single soldering process.

Cautions and warnings

- Switching spark gaps may become hot in case of longer periods of current stress (danger of burning).
- Electromagnetic fields and ionizing radiation may affect the electrical characteristics of the switching spark gaps. The impact of this kind of disturbances (inductive and capacitive comply, field distortion by nearby conductors) has to be avoided by circuit design.
- Switching spark gaps may be used only within their specified values. In case of overload, the head contacts may fail or the component may be destroyed.
- Switching spark gaps must be handled with care and must not be dropped.
- Damaged switching spark gaps must not be re-used.

Display of ordering codes for TDK Electronics products

The ordering code for one and the same product can be represented differently in data sheets, data books, other publications, on the company website, or in order-related documents such as shipping notes, order confirmations and product labels. **The varying representations of the ordering codes are due to different processes employed and do not affect the specifications of the respective products.** Detailed information can be found on the Internet under www.tdk-electronics.tdk.com/orderingcodes.

Important notes

The following applies to all products named in this publication:

1. Some parts of this publication contain **statements about the suitability of our products for certain areas of application**. These statements are based on our knowledge of typical requirements that are often placed on our products in the areas of application concerned. We nevertheless expressly point out **that such statements cannot be regarded as binding statements about the suitability of our products for a particular customer application**. As a rule we are either unfamiliar with individual customer applications or less familiar with them than the customers themselves. For these reasons, it is always ultimately incumbent on the customer to check and decide whether a product with the properties described in the product specification is suitable for use in a particular customer application.
2. We also point out that **in individual cases, a malfunction of electronic components or failure before the end of their usual service life cannot be completely ruled out in the current state of the art, even if they are operated as specified**. In customer applications requiring a very high level of operational safety and especially in customer applications in which the malfunction or failure of an electronic component could endanger human life or health (e.g. in accident prevention or life-saving systems), it must therefore be ensured by means of suitable design of the customer application or other action taken by the customer (e.g. installation of protective circuitry or redundancy) that no injury or damage is sustained by third parties in the event of malfunction or failure of an electronic component.
3. **The warnings, cautions and product-specific notes must be observed.**
4. In order to satisfy certain technical requirements, **some of the products described in this publication may contain substances subject to restrictions in certain jurisdictions (e.g. because they are classed as hazardous)**. Useful information on this will be found in our Material Data Sheets on the Internet (www.tdk-electronics.tdk.com/material). Should you have any more detailed questions, please contact our sales offices.
5. We constantly strive to improve our products. Consequently, **the products described in this publication may change from time to time**. The same is true of the corresponding product specifications. Please check therefore to what extent product descriptions and specifications contained in this publication are still applicable before or when you place an order.

We also **reserve the right to discontinue production and delivery of products**. Consequently, we cannot guarantee that all products named in this publication will always be available. The aforementioned does not apply in the case of individual agreements deviating from the foregoing for customer-specific products.

6. Unless otherwise agreed in individual contracts, **all orders are subject to our General Terms and Conditions of Supply**.
7. **Our manufacturing sites serving the automotive business apply the IATF 16949 standard**. The IATF certifications confirm our compliance with requirements regarding the quality management system in the automotive industry. Referring to customer requirements and customer specific requirements ("CSR") TDK always has and will continue to have the policy of respecting individual agreements. Even if IATF 16949 may appear to support the acceptance of unilateral requirements, we hereby like to emphasize that **only requirements mutually agreed upon can and will be implemented in our Quality Management System**. For clarification purposes we like to point out that obligations from IATF 16949 shall only become legally binding if individually agreed upon.

Important notes

8. The trade names EPCOS, CeraCharge, CeraDiode, CeraLink, CeraPad, CeraPlas, CSMP, CTVS, DeltaCap, DigiSiMic, ExoCore, FilterCap, FormFit, LeaXield, MiniBlue, MiniCell, MKD, MKK, MotorCap, PCC, PhaseCap, PhaseCube, PhaseMod, PhiCap, PowerHap, PQSine, PQvar, SIFERRIT, SIFI, SIKOREL, SilverCap, SIMDAD, SiMic, SIMID, SineFormer, SIOV, ThermoFuse, WindCap are **trademarks registered or pending** in Europe and in other countries. Further information will be found on the Internet at www.tdk-electronics.tdk.com/trademarks.

Release 2018-10