



Aluminum Electrolytic Capacitors

Vibration resistance and mounting notes

Date: December 2016

© EPCOS AG 2016. Reproduction, publication and dissemination of this publication, enclosures hereto and the information contained therein without EPCOS' prior express consent is prohibited.

EPCOS AG is a TDK Group Company.

Vibration resistance and mounting notes

Vibration resistance

Axial-lead and soldering star capacitors provide high vibration stability by means of a construction with extra rugged leads (\varnothing 1.0 mm) and strong internal fixation of the winding element in the capacitor can.

Basic construction

Axial-lead capacitor

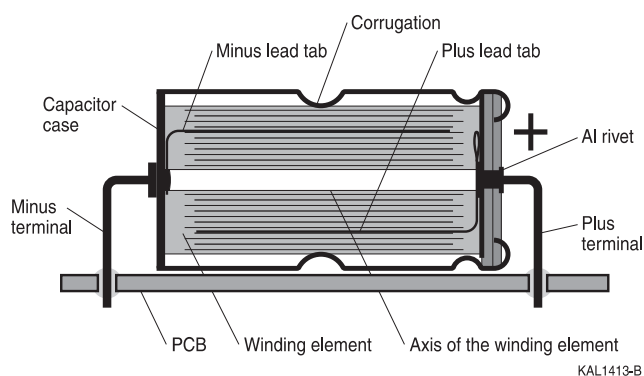

Soldering star capacitor

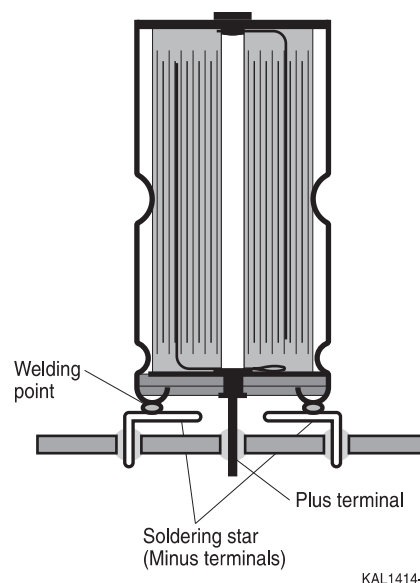

Axial-lead design with double-sided plates for horizontal mounting

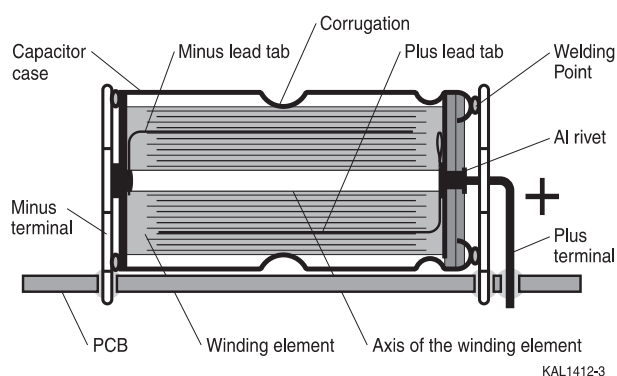

The winding element is fixed in the can by compression in an axial direction between the can base and the cover disk, and additionally by a corrugation of the can wall. This double fixation of the winding element prevents its movement in the can and thus protects the internal electrical connections against rupture (open circuit) under high vibration load. Welded connections between the internal lead tabs of the winding element and the capacitor case or the aluminum rivet in the cover disk additionally contribute to both the vibration stability and reliability of the internal electrical contact.

Vibration resistance and mounting notes

The soldering star capacitor and the axial-lead design with double-sided plates provide high vibration stability even without additional clamping on the PCB, thanks to the rugged plates (negative terminals) welded to the capacitor case.

Mounting notes

Axial-lead capacitors

The vibration resistance of axial-lead capacitors is specified according to the international standard IEC 60068-2, test Fc. The test method requires the capacitor to be mounted by its wire leads at a distance of 6 ± 1 mm from the case with additional clamping by the case. The specified maximum acceleration (10 ... 20 g) and displacement amplitude thus refer to the vibration resistance of the capacitor body under standardized rigid mounting conditions. When the capacitor is mounted without any fixation on the PCB, or in case of high vibration applications with common fixation on the PCB using special holders, potting or gluing, this will lead to additional vibration between the wire leads and the capacitor body as well as between the wire leads and the PCB. This additional vibration and the potential resonance depend strongly on the mounting conditions and the PCB design. The maximum vibration resistance of the PCB with mounted components, or the complete device, should consequently be verified separately by the user. Special axial-lead capacitor designs with increased vibration resistance are available on request.

Soldering star capacitors and axial-lead design with double-sided plates

Both the soldering star and the double side-plated axial-lead capacitors are designed for mounting without special holders. The soldering star capacitor is designed for mounting in an upright position whereas the axial-lead design with double-sided plates is for the horizontal position on a PCB. As the internal capacitor construction (winding and case constructions except for the terminals) is identical in both cases, the same IEC vibration specifications apply to the soldering star capacitor and to the axial-lead design with double-sided plates clamped by the case. However, the vibration resistance of these designs mounted without a holder is significantly higher than that of the axial-lead capacitors due to the rigid and robust plate terminals. Furthermore, the axial-lead design with double-sided plates provides improved vibration stability due to its low center of gravity and fourfold connection to the PCB. As with the axial-lead capacitor, the vibration resistance of the complete PCB and the device has to be verified separately by the user. In applications where the soldering star capacitor and the axial-lead type with double-sided plates are additionally glued to the housing cover of the device, it must be noted that this connection generates additional forces with respect to the capacitor case which could also negatively affect the vibration resistance in some cases. This possible effect should be considered in the design of the PCB and the device. In general, we recommend users to simulate or test the vibration resistance of the PCB/device in the early stage of development in order to ensure the right design of the device with selection of the appropriate capacitor type.