



Film Capacitors

General technical information

Date: June 2018

© EPCOS AG 2018. Reproduction, publication and dissemination of this publication, enclosures hereto and the information contained therein without EPCOS' prior express consent is prohibited.

EPCOS AG is a TDK Group Company.

General technical information

This data book describes fixed capacitors with plastic film dielectrics, also termed **film capacitors** or **FK capacitors**.

1 Classification of film capacitors

1.1 Classification by dielectric

The characteristics and application possibilities of film capacitors are affected so strongly by the dielectric used that capacitors are grouped and designated according to the type of dielectric.

Short identification codes for the type of construction, describing the dielectric and the basic technology applied, are defined in standard DIN EN 60062:2005.

The last character of the short code indicates the type of dielectric:

T \triangleq Polyethylene terephthalate (PET)

P \triangleq Polypropylene (PP)

N \triangleq Polyethylene naphthalate (PEN)

An M (\triangleq metallization) is prefixed to the short identification code of capacitors with metallized films.

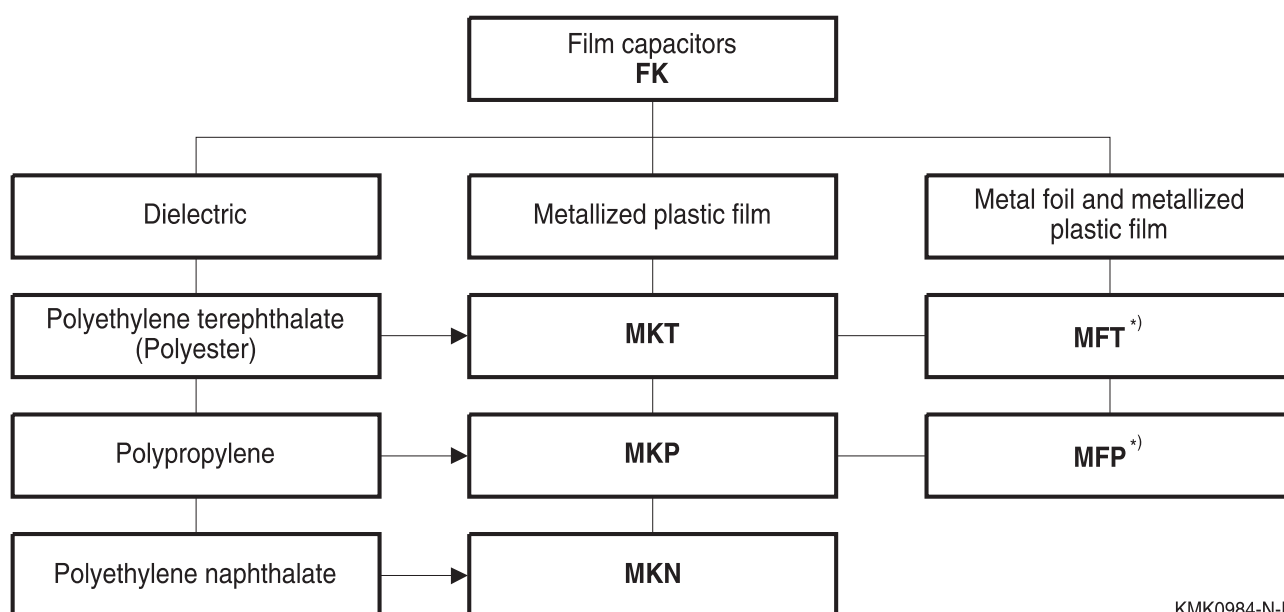

Figure 1
Classification of film capacitors in DIN EN 60062:2005

^{*)} MFP and MFT capacitors are constructed using a combination of metal foils and metallized plastic films. They are not covered by DIN EN 60062:2005.

General technical information

Characteristics of plastic film dielectrics (generalized typical values)

The following table is a summary of important technical data.

Dielectric		PP	PET	PEN	Refer to section
Dielectric constant (ϵ_r)		2.2	3.2	3.0	
C drift with time ($i_z = \Delta C/C$)	%	3	3	2	2.2.5
C temperature coefficient α_c	$10^{-6}/K$	-250	+600	+200	2.2.2
C humidity coefficient β_c (50 ... 95%)	$10^{-6}/\%$ r.h.	40 ... 100	500 ... 700	700 ... 900	2.2.3
Dissipation factor (1 kHz)		0.0005	0.0050	0.0040	2.3.1
Time constant	s	100 000	25 000	25 000	2.4.1, 2.4.2
Dielectric absorption	%	0.05	0.2	1.2	6.3

1.2 Classification by film and foil arrangements

For a better understanding of the differences in the internal structure of capacitors, figure 2 shows some typical film and foil arrangements.

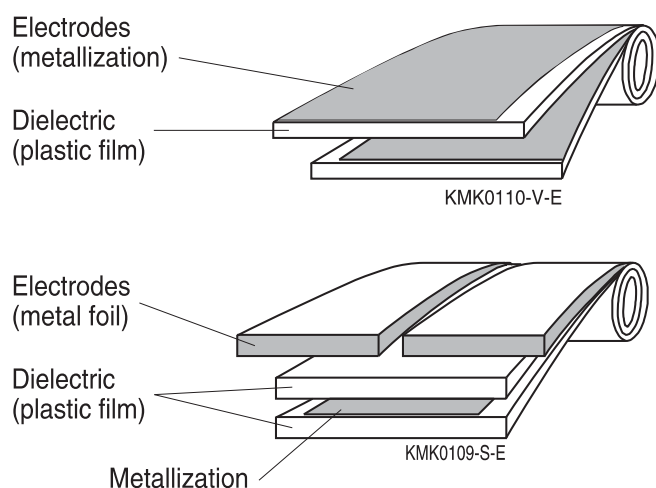

Figure 2
Examples of typical film and foil arrangements

General technical information

Figure 3 shows the relation between various film/foil arrangements and the capacitor types.

Simple connection	Film and foil arrangements	Types
 KMK0986-5	 KMK0987-D	MKP MKT MKN EMI suppression capacitors
 KMK0411-M	 KMK0988-L	
 KMK0431-2	 KMK0415-K	
 KMK0429-Q	 KMK0416-T	
 KMK0411-M	 KMK0413-4	
Metal foil KMK0989-U	Metallized plastic film KMK0990-X	Plastic film without metallization KMK0991-6

Figure 3
Schematic film and foil arrangements of various capacitor types

1.3 Classification by construction

EPCOS FK capacitors are produced using either winding methods or stacking methods.

1.3.1 Wound technology

In the conventional production process, capacitors are made by individually rolling the metallized films or the film/foils into cylindrical rolls and then covering them with an insulating sleeve or coating.

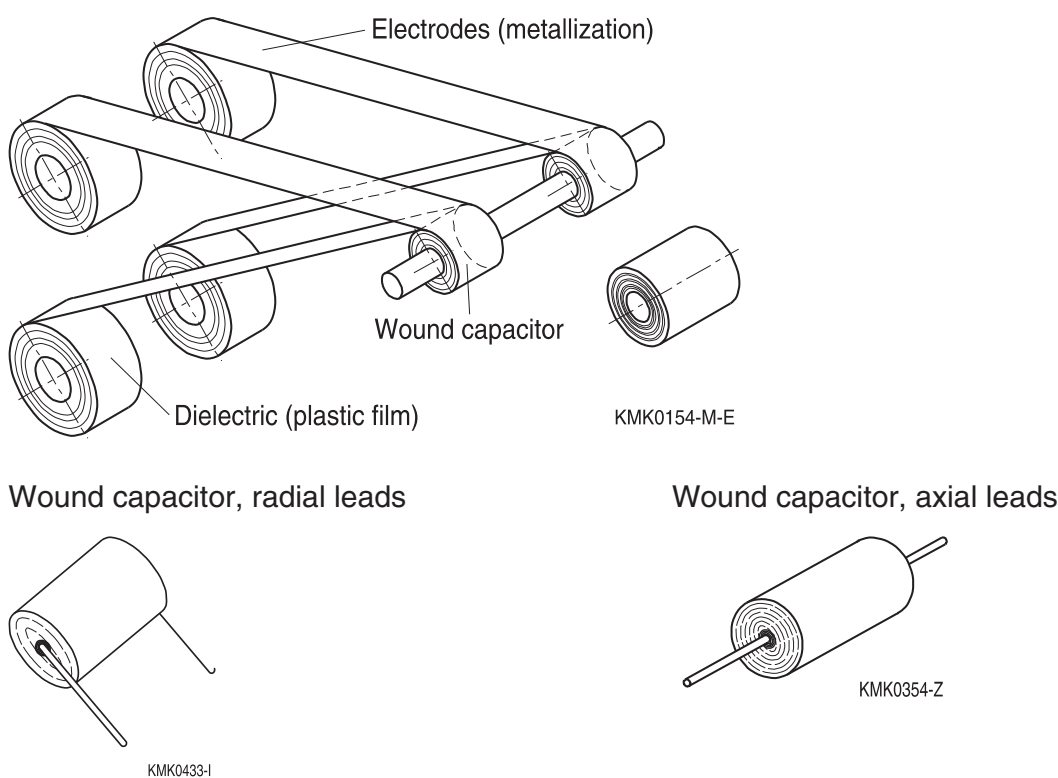

Figure 4
Conventional production process in wound technology

In the MKT, MKP and MFP type series, our production range includes capacitors with space-saving flattened wound bodies with insulating coatings or inside plastic casings, as well as cylindrical wound capacitors. Flat windings are produced by compressing the cylindrical rolls before they are placed in casings, so that the casing form is optimally used.

1.3.2 Stacked-film technology

In stacked-film production technology, large rings of metallized film are wound onto core wheels with diameters up to 60 cm. In this way the "master capacitors" are produced under well-defined and constant conditions.

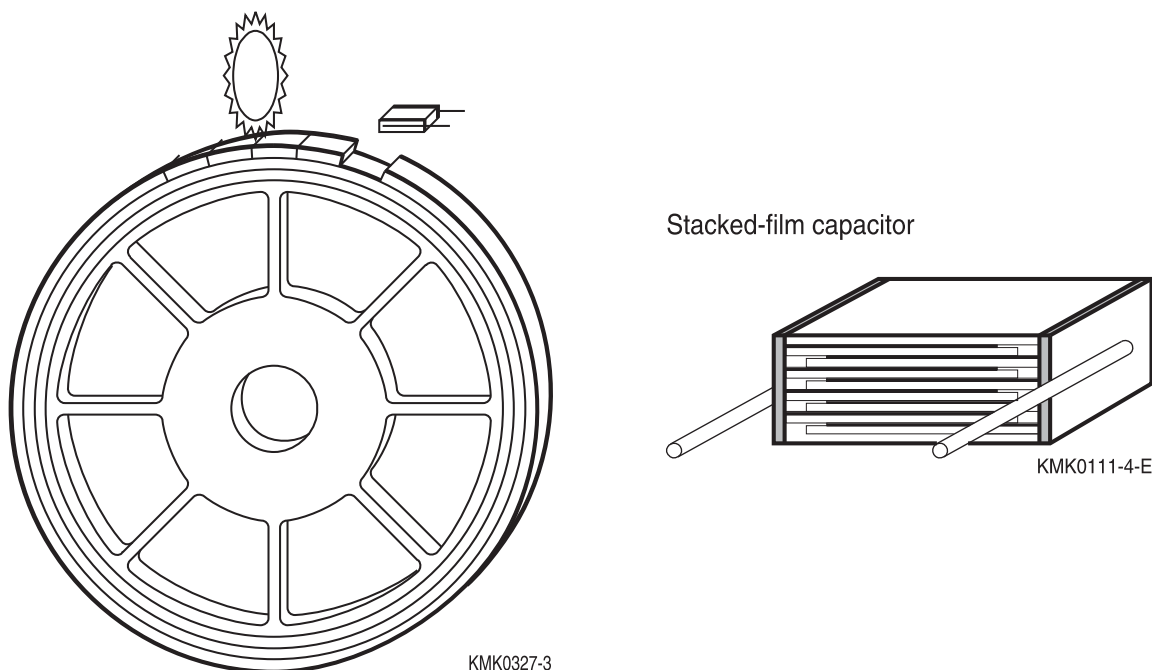

Figure 5
Stacked-film production technology

As a result, the capacitor production lots obtained when the rings are sawed apart to produce the actual stacked-film capacitor bodies are especially homogeneous.

- The **pulse handling capabilities** of stacked-film capacitors are of a particular advantage. Each individual layer acts as a single capacitor of small capacitance, so any damage to the contacts due to overloading is restricted to the layers concerned, which might get disconnected. Therefore the total capacitance can decrease slightly, without further affecting the performance and reliability of the part.
- Additionally, uncoated stacked-film capacitors (SilverCap™) offer the special advantage that they can be adapted to customer design requirements. A wide range of sizes can be offered without considering case size standards or provide special tools for new cases.

General technical information

Design rules for SilverCaps:

For a fixed lead spacing e (and thus capacitor length "l"), the capacitor width "w" and height "h" can be adjusted within the following ranges:

Lead spacing e		7.5 mm	10 mm	15 mm	22.5 mm	27.5 mm
Width "w" (mm)	min. / max.	2.5 / 11	2.5 / 11	4 / 15	4 / 18	4 / 18
Height "h" (mm)	min. / max.	4 / 13	4 / 13.5	4.5 / 20	6 / 25	6 / 25

Whatever the dimensions, the volume must remain approximately the same.

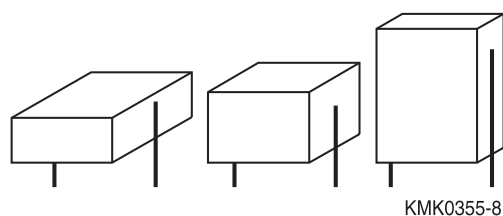

Figure 6

Examples of special capacitor dimensions for the same capacitance and voltage ratings

General technical information

1.4 Classification by finish and terminal

A variety of standard designs with corresponding types of terminals are available to suit different applications and operating environments.





Design	Schematic	Stacked-film	Wound
Radial leads			
Uncoated (SilverCap)		Yes	No
Coated		Yes	Yes
Sealed in plastic case (boxed)		Yes	Yes
Axial leads			
Cylindrical winding		No	Yes
Flat winding		No	Yes
SMD plates			
Uncoated/wrapped		Yes	No
Others (customized)			
Strap terminals		Yes	Yes

Figure 7
Capacitor designs

General technical information

2 Electrical characteristics

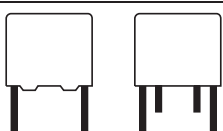
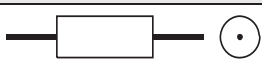
2.1 Equivalent circuit diagram

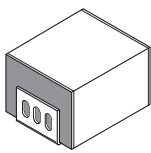
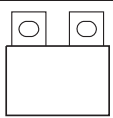
Any real capacitor can be modeled by the following schematic:

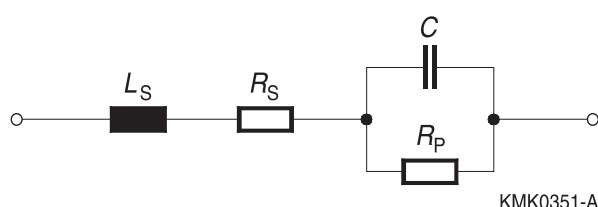

Figure 8
Real capacitor model

L_S Series inductance

R_S Series resistance, due to contacts (leads, sprayed metal and film metallization)

R_P Parallel resistance, due to insulation resistance

C Capacitance

C , R_S and L_S are magnitudes that vary in the frequency domain (AC).

R_P is a magnitude defined in DC (insulation resistance).

2.2 Capacitance

2.2.1 Rated capacitance / measuring conditions

Capacitance is the amount of electrically charged carriers a capacitor can store per unit of voltage. The **rated capacitance** C_R of a capacitor is the value for which it is designed, and that is indicated on it.

Capacitance is measured under standard conditions to IEC 60068-1:2013. In case of doubt, stricter reference conditions are defined in sub-clause 5.2 of the same specification.

Measuring conditions	Standard conditions	Reference conditions
Temperature	15 ... 35 °C	(23 ±1) °C
Relative humidity	45 ... 75%	(50 ±2) %
Ambient atmospheric. pressure	86 ... 106 kPa	86 ... 106 kPa
Frequency	1 kHz	1 kHz
Voltage	0.03 · V_R (max. 5 V)	0.03 · V_R (max. 5 V)

Prior to being measured, a capacitor must be stored under measuring conditions until the entire capacitor has reached the measuring temperature and humidity.

The **capacitance tolerance** is the permissible relative deviation of the real capacitance from the rated value, expressed in percent. The measuring conditions are the same as for the rated capacitance. The codes for capacitance tolerance are defined in section "capacitor markings" (see page).

2.2.2 Variation of capacitance with temperature

Capacitance will undergo a **reversible change** within a range of temperatures between the upper and lower category temperatures. The gradient of the capacitance/temperature curve is given by the **temperature coefficient** α_c of the capacitance, which is defined as the average capacitance change, in relation to the capacitance measured at $(20 \pm 2)^\circ\text{C}$, occurring within the temperature range T_1 to T_2 . It is expressed in units of $10^{-6}/\text{K}$.

$$\alpha_c = \frac{C_2 - C_1}{C_3 \cdot (T_2 - T_1)}$$

C_1 Capacitance measured at temperature T_1

C_2 Capacitance measured at temperature T_2

C_3 Reference capacitance measured at $(20 \pm 2)^\circ\text{C}$

The temperature coefficient is essentially determined by the properties of the dielectric, the capacitor construction and the manufacturing parameters. Polypropylene capacitors have negative temperature coefficients, polyester capacitors have positive temperature coefficients.

Dielectric		PP	PET	PEN
C Temperature coefficient α_c	$10^{-6}/\text{K}$	-250	+600	+200

Reversible changes of capacitance with temperature are usually expressed as $\Delta C/C$. Figure 9 shows typical temperature characteristics of different capacitor styles.

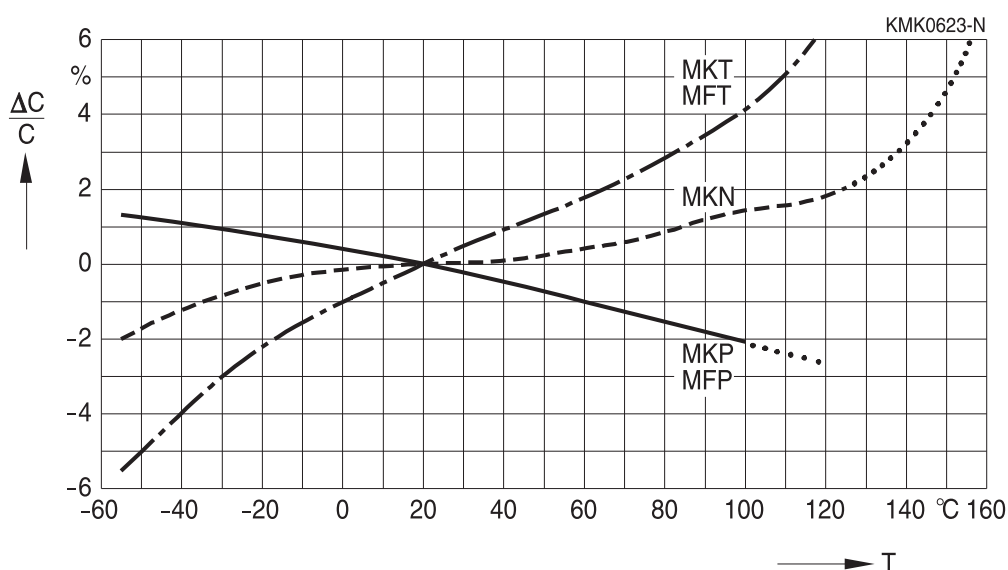

Figure 9
Relative capacitance change $\Delta C/C$ vs. temperature T (typical values)

General technical information

If a capacitor is subjected to a temperature cycle from the reference temperature to T_{\min} , then up to T_{\max} and back to the reference temperature, a small **irreversible change** may be observed between the initial and the final capacitance (cf. figure 10). This deviation is called **temperature cyclic capacitance drift**, and is expressed as a percentage of the reference capacitance. For film capacitors it is usually very small.

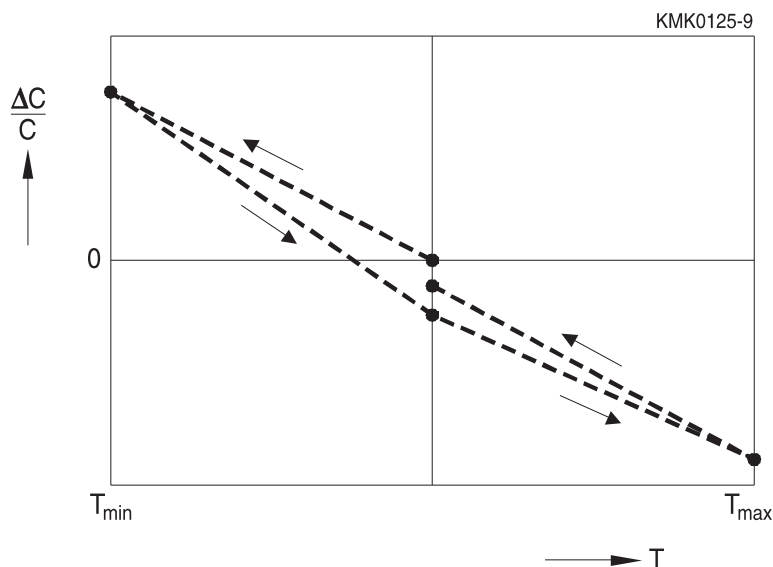

Figure 10
Capacitance change $\Delta C/C$ vs. temperature T (schematic curve)

When performing measurements, it must generally be taken into consideration that every temperature change is accompanied by a relative humidity change, which will affect the measurement (as described in section 2.2.3). Changes caused by humidity variations remain within the scatter limits specified for α_c if measurements are carried out under standard conditions and the temperature cycles are not too long.

General technical information

2.2.3 Variation of capacitance with humidity

The capacitance of a plastic film capacitor will undergo a **reversible change** of value in relation to any change in the ambient humidity. Depending on the type of capacitor design, both the dielectric and the effective air gap between the films will react to changes in the ambient humidity, which will thus affect the measured capacitance.

The **humidity coefficient** β_c is defined as the relative capacitance change determined for a 1% change in humidity (at constant temperature).

$$\beta_c = \frac{2 \cdot (C_2 - C_1)}{(C_2 + C_1) \cdot (F_2 - F_1)}$$

C_1 Capacitance at relative humidity F_1
 C_2 Capacitance at relative humidity F_2

Dielectric		PP	PET	PEN
C Humidity coefficient β_c (50 ... 95%)	$10^{-6}/\%$ r.h.	40 ... 100	500 ... 700	700 ... 900

The values of β_c given in table are valid for a relative humidity range of 50% to 95%. At relative humidity below 30%, the humidity coefficient is relatively low. Wide variations are to be expected at relative humidity above 85%.

Figure 11 shows typical capacitance/humidity characteristics of different capacitor styles.

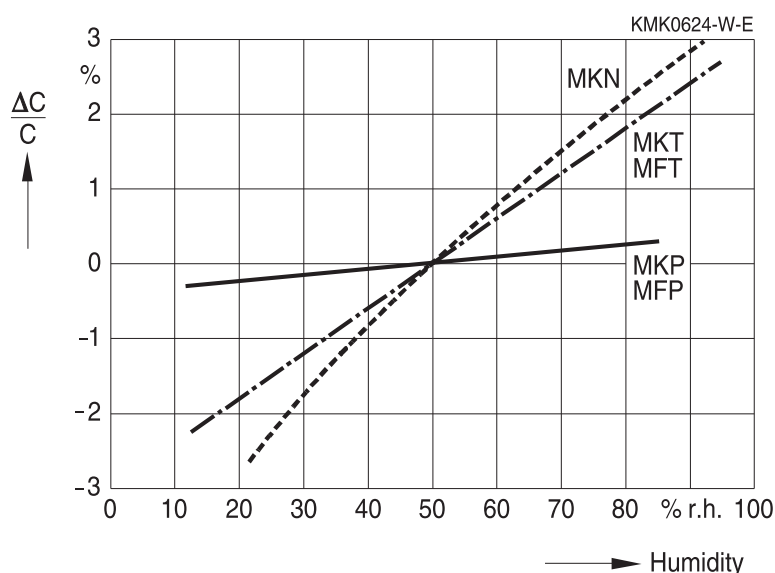

Figure 11
Relative capacitance change $\Delta C/C$ vs. relative humidity (typical values)

Irreversible effects due to humidity are described in section 4.3.

2.2.4 Variation of capacitance with frequency

As figure 12 shows, in polypropylene capacitors (PP – MKP, MFP), the capacitance remains virtually unaffected by frequency up to 1 MHz. In polyester capacitors (PET – MKT) and especially in PEN capacitors (polyethylene naphthalate, MKN), the effect of frequency is more noticeable:

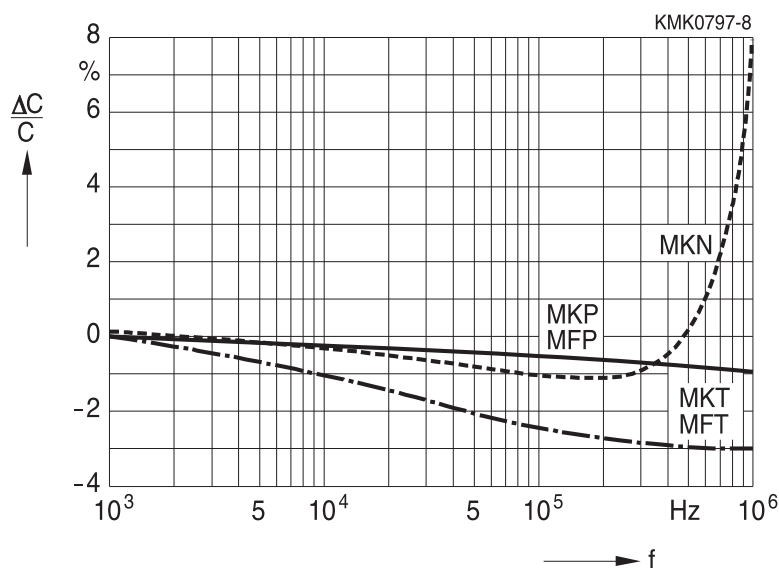

Figure 12
Relative capacitance change $\Delta C/C$ vs. frequency f (typical example)

Additionally, in the vicinity of the natural resonant frequency of the capacitors, self-inductance leads to an additional decrease of impedance.

This has the same effect as an increase in capacitance (refer to section 2.6).

2.2.5 Variation of capacitance with time

In addition to the changes described, the capacitance of a capacitor is also subjected to irreversible changes known as drift $i_z = |\Delta C/C|$. The values stated for capacitance drift (see table below) are maximum values and refer to a two-year period and a temperature up to 40 °C. Here the reversible effects of temperature changes (β_c) and changes in relative humidity (α_c) are not taken into consideration.

Drift is stabilized over time and thus provides the long-term stability of capacitance. However, it may exceed the specified values if a capacitor is subjected to frequent, large temperature changes in the vicinity of the upper category temperature and relative humidity limits.

Dielectric	PP	PET	PEN
Capacitance drift i_z (typical values)	3%	3%	2%

2.3 ESR and dissipation factor

Under an AC voltage signal of specified frequency, the equivalent circuit diagram in section 2.1 can be simplified to a series connection of the capacitance C, an **equivalent series resistance (ESR)** and the series inductance L_S .

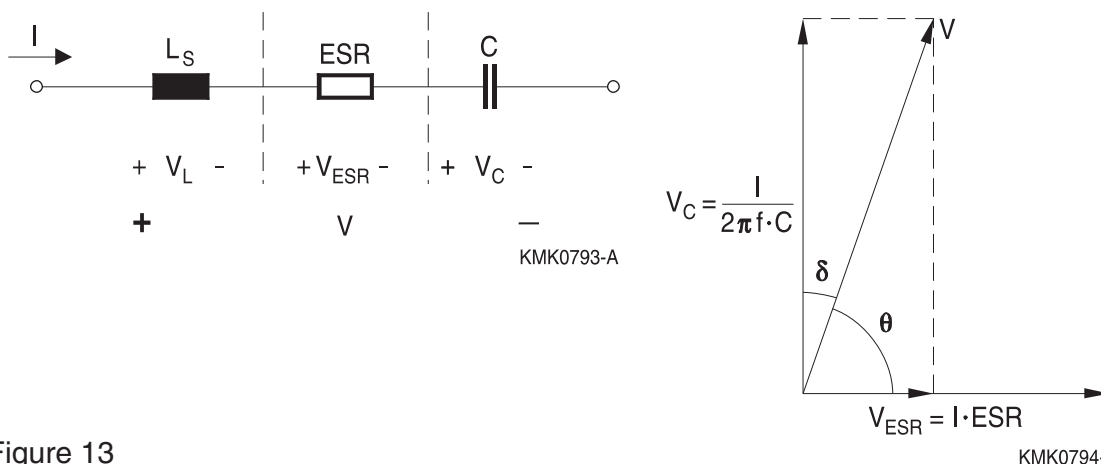

Figure 13
Simplified capacitor model for AC. Complex voltage calculation.

For frequencies well below the natural resonant frequency (L_S , V_L is very small), due to the ESR the phase shift between voltage and current is slightly less than 90° . The difference between the phase angle θ and 90° is the defect angle δ , which is measured through the **dissipation factor** $\tan \delta$, i.e. the ratio of the equivalent series resistance ESR to the capacitive reactance $X_C = 1/2\pi f \cdot C$.

$$\tan \delta = ESR \cdot 2\pi f \cdot C$$

It can easily be deduced that the dissipation factor is also the ratio of effective power (i.e. power dissipation) to reactive power. Power dissipation can be expressed as a function of voltage V_{ESR} across the equivalent series resistance ESR, or the current I through it:

$$P = \frac{V_{ESR}^2}{ESR} = ESR \cdot I^2$$

Since

$$V_{ESR}^2 = \frac{ESR^2}{ESR^2 + \left(\frac{1}{2\pi f \cdot C}\right)^2} \cdot V^2$$

and since for film capacitors $\tan \delta = 2\pi f \cdot C \cdot ESR \ll 0.1$

$$V_{ESR}^2 = ESR^2 \cdot (2\pi f \cdot C)^2 \cdot V^2$$

the power can be expressed as

$$P = 2\pi f \cdot C \cdot \tan \delta \cdot V^2 \quad \text{or} \quad P = (2\pi f \cdot C)^2 \cdot ESR \cdot V^2$$

Both ESR and $\tan \delta$ are important because they dictate the **power dissipation** of a capacitor and thus its **self-heating**.

2.3.1 Measuring conditions for dissipation factor

The generic standards and the sectional standards specify the same measuring conditions for dissipation factor $\tan \delta$ as for capacitance (refer to chapter 2.2.1). 1 kHz is the standard measuring frequency. For MKT, MFP and MKP film capacitors with $C_R \leq 1 \mu\text{F}$, additional measuring frequencies of 10 kHz or 100 kHz are used to determine the dissipation factor.

2.3.2 Variation of dissipation factor with frequency

If the inductance L_S is neglected and for frequencies well below the natural resonant frequency, the dissipation factor $\tan \delta$ is a combination of a parallel component $\tan \delta_P$, a series component $\tan \delta_S$ and a dielectric component $\tan \delta_D$:

$$\tan \delta = \tan \delta_P + \tan \delta_S + \tan \delta_D$$

$$\tan \delta_P = \frac{1}{R_P \cdot 2\pi f \cdot C}$$

$$\tan \delta_S = R_S \cdot 2\pi f \cdot C$$

$\tan \delta_D$ = a characteristic of the dielectric

The **parallel component $\tan \delta_P$** depends on the insulation resistance (parallel resistor R_P in figure 8). Due to the extremely high values of insulation resistance, this component is negligible in the entire frequency range even at very low frequencies ($f \ll 1 \text{ kHz}$).

The **dielectric component $\tan \delta_D$** is a measure of the losses associated with the dielectric (i.e. the energy wasted to polarize and repolarize the dielectric in two opposite directions for successive half-cycles of the AC voltage). It determines self-heating at low frequencies:

- In polypropylene capacitors, $\tan \delta_D$ remains approximately constant with frequency and will typically result in a value of approx. 10^{-4} .
- In polyester capacitors, $\tan \delta_D$ is considerably greater and increases with frequency. So these capacitors display noticeably higher, overall dissipation factor at lower frequencies (cf. figure 14).

The **series component $\tan \delta_S$** is determined by the series resistance (R_S in figure 8), which represents the sum of the contact resistances and the resistances of leads, metal layers and electrode foils. This component increases rapidly with frequency until it becomes the dominating component in the $\tan \delta$ curve for high frequencies. It also increases with capacitance (cf. figure 15).

General technical information

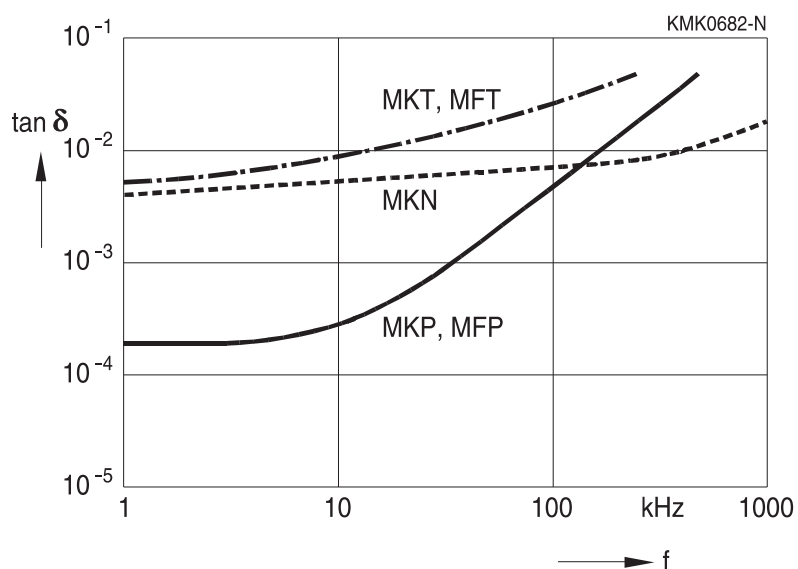

Figure 14
Frequency dependence of dissipation factor $\tan \delta$, e.g. for $C_R = 0.10 \mu\text{F}$ (typical behavior)

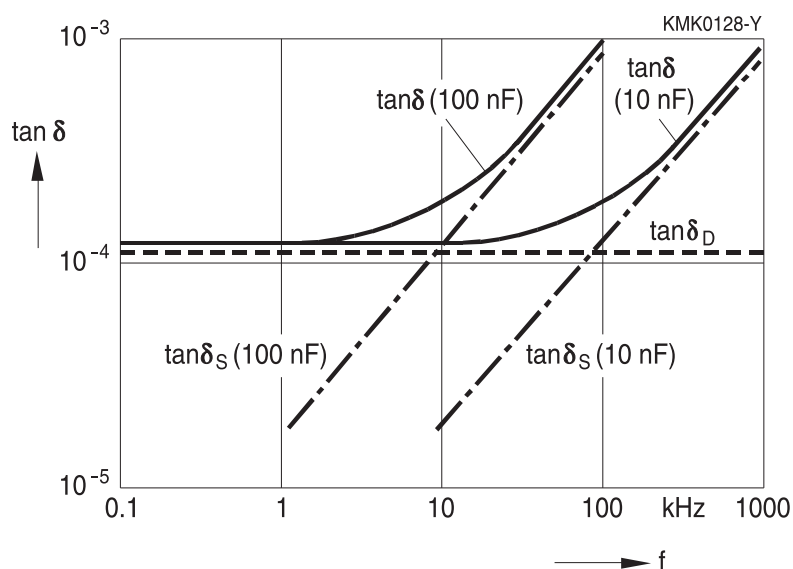

Figure 15
Dissipation factor $\tan \delta$ vs. measuring frequency f (schematic representation using two polypropylene capacitors of different capacitance as examples)

2.3.3 Variation of dissipation factor with temperature, humidity and voltage

The dissipation factor of capacitors with a polypropylene dielectric is largely unaffected by temperature, whereas polyester capacitors show a characteristic dissipation factor minimum at approx. 80 °C (at 1 kHz).

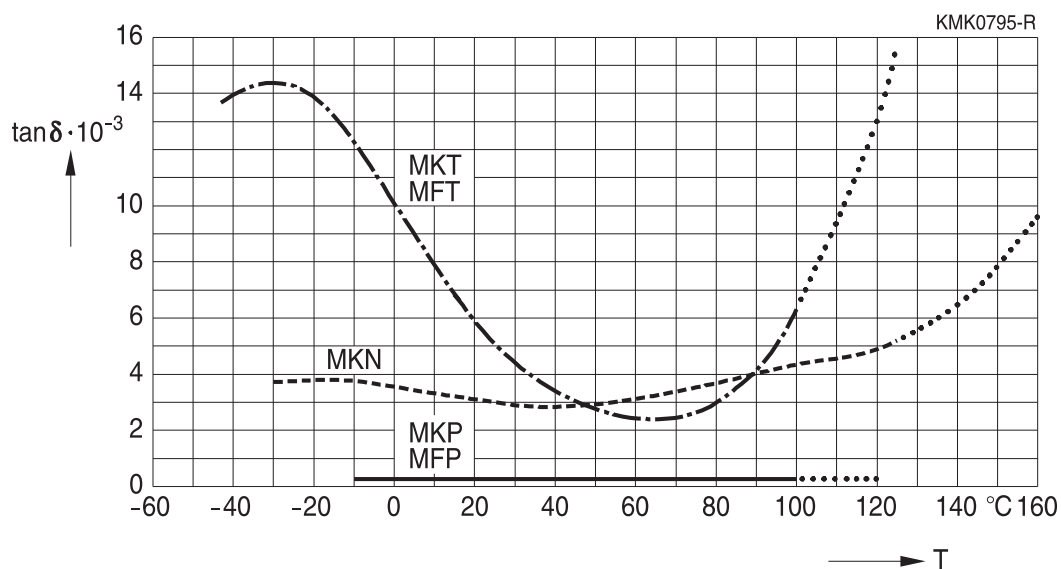

Figure 16
Dissipation factor $\tan \delta$ vs. temperature T for $f = 1$ kHz (typical values)

The dissipation factor values may increase as well under humid conditions. Under normal operation range variation of dissipation factor with voltage is negligible.

2.3.4 Variation of ESR with frequency

From the definition of $\tan \delta$, ESR can be expressed as:

$$\text{ESR} = \frac{\tan \delta}{2\pi f \cdot C}$$

Thus ESR comprises all the phenomena that can contribute as resistivity, which have been described for the dissipation factor (see 2.3.2). Figure 17 shows a general frequency response for a film capacitor:

- At very low frequencies, leakage is prevalent (range not represented).
- At low frequencies, ESR is dominated by the dielectric losses, decreasing roughly as f^{-1} .
- At medium to high frequencies, losses in the conductors are dominant and ESR becomes relatively constant.
- At very high frequencies (>10 MHz) ESR increases by \sqrt{f} due to the skin effect.

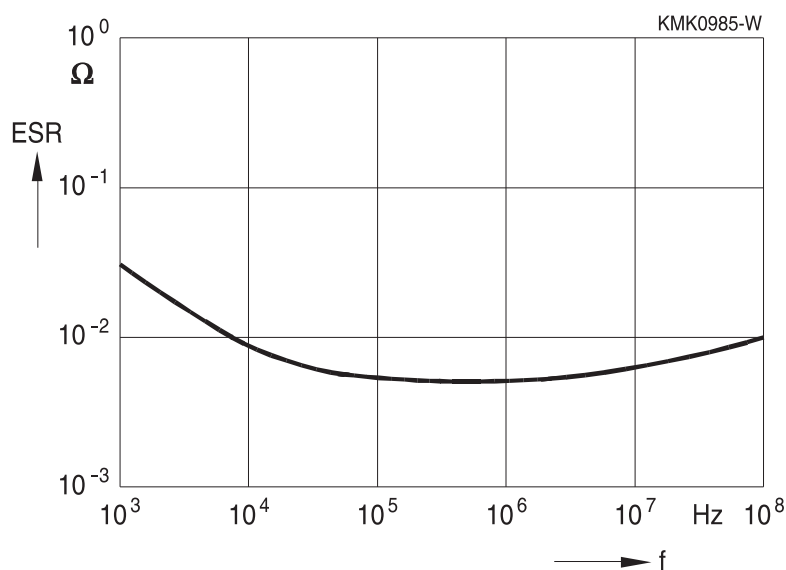

Figure 17
ESR vs. frequency for an MKT capacitor

ESR variations with temperature and humidity follow those of dissipation factor.

General technical information

2.4 Insulation resistance

2.4.1 Measuring conditions

The insulation resistance R_{ins} of a capacitor is a measure of its resistivity in DC. Under a stationary DC voltage, a leakage current flows through the dielectric and over the capacitor surfaces.

R_{ins} is measured by determining the ratio of the applied DC voltage to the resulting leakage current flowing through the capacitor, once the initial charging current has ceased (typically after a period of 1 min \pm 5 s).

The measuring voltage depends on the rated voltage. It is specified in IEC 60384-1:2016, section 4.5.2:

Rated voltage V_R of capacitor	Measuring voltage
$10 \text{ V} \leq V_R < 100 \text{ V}$	$(10 \pm 1) \text{ V}^{1)}$
$100 \text{ V} \leq V_R < 500 \text{ V}$	$(100 \pm 15) \text{ V}$
$500 \text{ V} \leq V_R$	$(500 \pm 50) \text{ V}$

The specified measuring temperature is 20 °C. At other temperatures, a correction shall be made to the measured value to obtain the equivalent value for 20 °C by multiplying the measured result by the appropriate correction factor.

Measuring temperature in °C	Correction factors (average values) according to the sectional specification		
	MKT, MFT	MKN	MKP, MFP
15	0.79	0.79	0.75
20	1.00	1.00	1.00
23	1.15	1.15	1.25
27	1.38	1.38	1.50
30	1.59	1.59	1.75
35	2.00	2.00	2.00

In case of doubt a referee measurement at 20 °C and (50 \pm 2)% relative humidity is decisive.

In the data sheets for the individual types, the insulation resistance R_{ins} is given as a minimum as-delivered value and as a limit value attained after the "damp heat, steady-state" test.

For capacitors with capacitance ratings $>0.33 \mu\text{F}$ the insulation is given in terms of a **time constant**.

$$\tau = R_{ins} \cdot C_R \text{ (in s)}$$

(conversion tip: $1 \text{ M}\Omega \cdot \mu\text{F} \triangleq 1 \text{ s}$)

1) When it can be demonstrated that the voltage has no influence on the measured result, or that a known relationship exists, measurements can be carried out at any voltages up to the rated voltage V_R (in case of referee measurements, 10 V shall be used)

2.4.2 Factors affecting insulation resistance

As could already be deduced from the correction factor table in section 2.4.1, the insulation resistance is affected by temperature. Figure 18 shows the typical behavior of individual types.

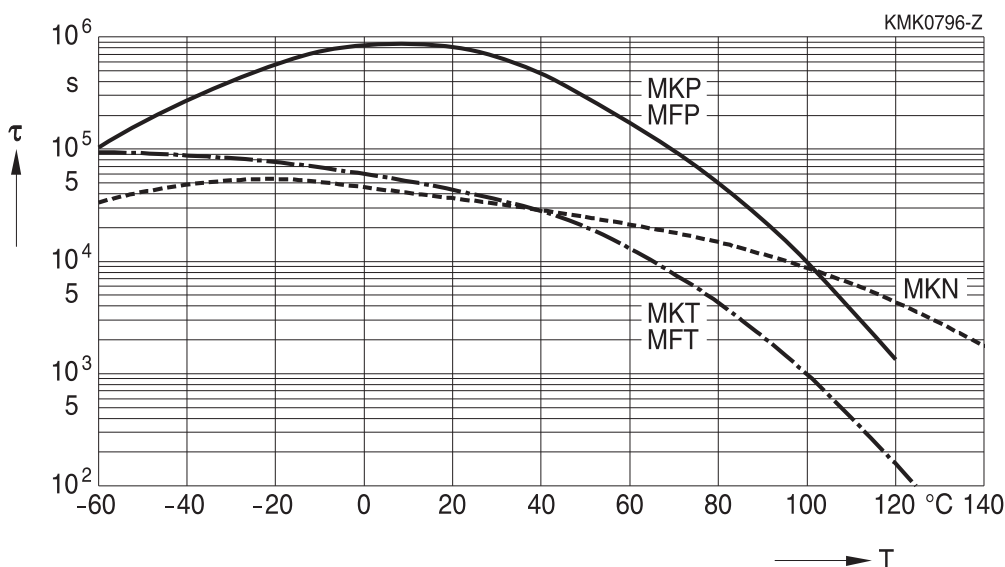

Figure 18
Insulation as self-discharge time constant τ ($= R_{ins} \cdot C_R$) in s ($\triangleq M\Omega \cdot \mu F$) vs. temperature T (typical values)

Insulation resistance is also affected significantly by humidity (as humidity increases, insulation resistance decreases).

2.5 Self-inductance

The self-inductance or series inductance L_S of a film capacitor is due to the magnetic field created by the current in the film metallization and the connections. It is thus determined by the winding structure, the geometric design and the length and thickness of the contact paths.

As far as possible, all capacitors described in this data book are constructed with low-inductance bifilar electrode current paths or extended-foil contacts, and thus feature very low inductance.

A general rule for deducing L_S states that the maximum value is 1 nH per mm of lead length and capacitor length. L_S can also be calculated from the resonant frequency (see 2.6).

2.6 Impedance, resonant frequency

The impedance Z represents the component's opposition to current flow and is both resistive and reactive in nature. It is thus of particular importance in AC and ripple current filtering.

From the capacitor model in figure 13, Z is defined as the magnitude of the vectorial sum of ESR and the total reactance (inductive reactance minus capacitive reactance):

$$Z = \sqrt{ESR^2 + \left(2\pi f \cdot L_S - \frac{1}{2\pi f \cdot C}\right)^2}$$

As can be seen in figure 19, Z is strongly frequency dependent:

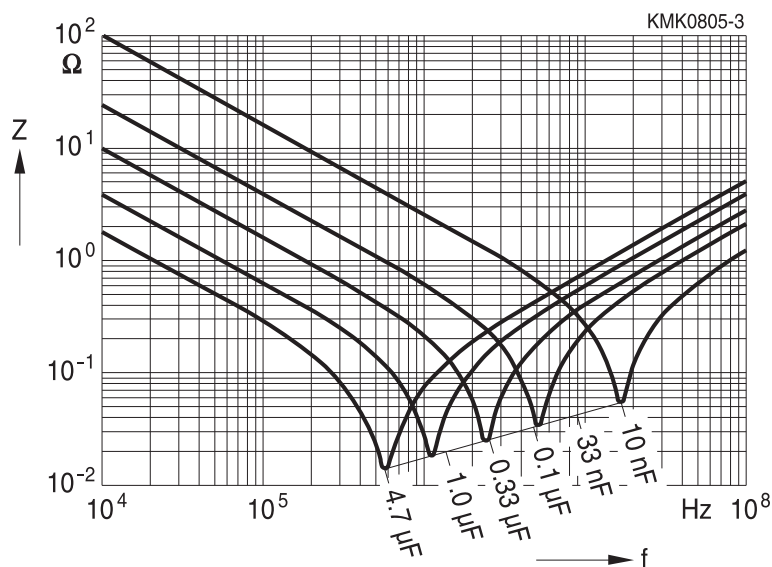

Figure 19
Typical impedance characteristics of film capacitors

At low frequencies, the capacitive reactance $X_C = 1/2\pi f \cdot C$ prevails, whereas at very high frequencies the inductive reactance $X_L = 2\pi f \cdot L_S$ is dominant. When capacitive reactance equals inductive reactance, natural resonance occurs. At this point the reactances cancel each other out and impedance equals ESR. The natural resonant frequency is therefore given by:

$$f_{res} = \frac{1}{2\pi \cdot \sqrt{C \cdot L_S}}$$

The frequency range of natural resonance (also termed self-resonance) as a function of capacitance can be read off the following diagram.

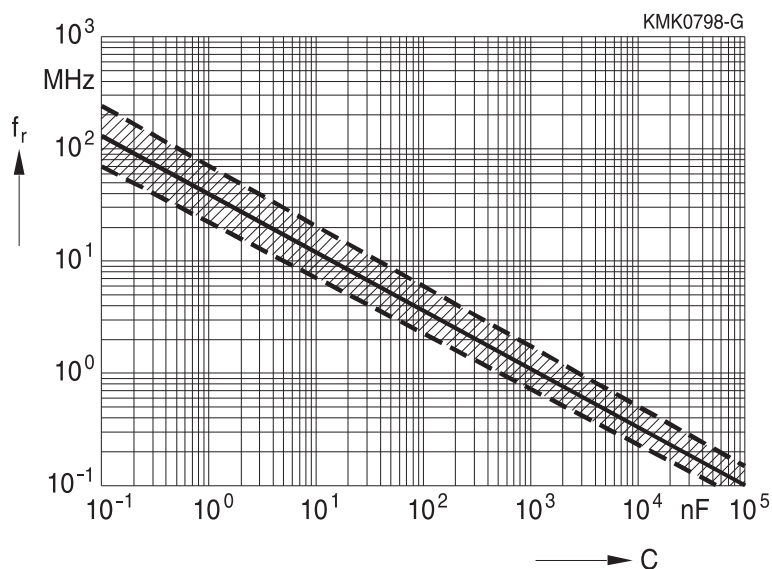

Figure 20
Resonant frequency f_{res} versus capacitance C (typical values)

General technical information

3 Operation

3.1 DC voltage

3.1.1 Rated voltage

The **rated voltage** V_R is the DC voltage for which a capacitor is designed. It is defined as the maximum DC voltage that may be applied continuously to the capacitor terminals at any temperature between the lower category temperature T_{min} and the rated temperature T_R (see 3.1.3).

V_R is dependent on the dielectric material and the film thickness.

3.1.2 DC test voltage

The DC test voltage is the voltage to which a capacitor is subjected in the course of the final inspection test in production (100% electrical inspection). Its value and application time are stated for each type. For details of the test circuit and equipment, refer to IEC 60384-1:2016, section 4.6.

The test voltage may be repeated once as an incoming goods inspection test. It also applies to the qualification approval test (duration: 60 s) and to lot-by-lot quality conformance inspection (duration ≤ 2 s). An exception is made in the case of EMI suppression capacitors, for which the (lower) test voltages specified in the respective standards apply.

3.1.3 Maximum DC voltage vs. temperature

The **category temperature range** of a capacitor gives the range of ambient temperatures at which a capacitor can operate continuously. It is defined by the upper and lower category temperatures (T_{min} and T_{max}).

Within this range, there is a **rated temperature** T_R defined as the maximum ambient temperature at which a capacitor can operate continuously under the rated voltage V_R . It is dependent on the dielectric material.

Dielectric	T_R
Polyester (PET), Polypropylene (PP)	85 °C
Polyethylene naphthalate (PEN)	125 °C

General technical information

The **category voltage** V_C is the maximum voltage that can be applied continuously to a capacitor for a given temperature. It is defined as follows:

- Between the lower category temperature T_{min} and the rated temperature T_R , the maximum continuous voltage is the rated voltage V_R , i.e. $V_C = V_R$.
- Between the rated temperature T_R and the upper category temperature T_{max} , a derating factor (typically 1.25% per °C for PET and PP, 0.8% per °C for PEN) needs to be applied. V_C is expressed as a fraction of the rated voltage, as shown in figure 21.

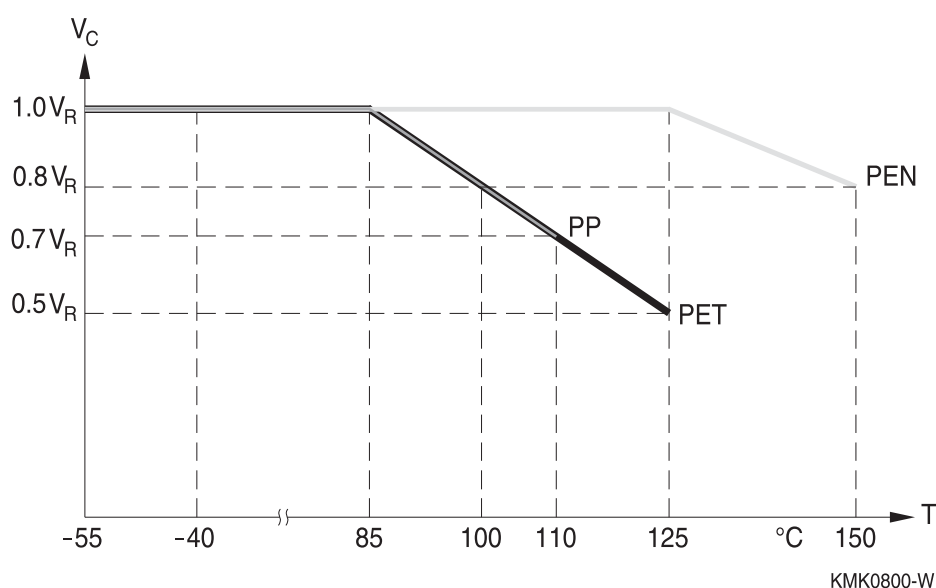

Figure 21
Maximum permissible continuous voltage vs. temperature T

3.2 AC voltage

3.2.1 Rated AC voltage

The **rated AC voltage** V_{RMS} is defined as the maximum RMS voltage at specified frequency (usually 50 Hz) that may be applied continuously to the terminals of a capacitor at any temperature between the lower category temperature T_{min} and the rated temperature T_R .

3.2.2 Maximum AC voltage vs. frequency

The ability of a capacitor to withstand a continuous (sine-wave) alternating voltage load V_{RMS} or alternating current I_{RMS} is a function of the frequency and is limited by 3 different factors (figure 22):

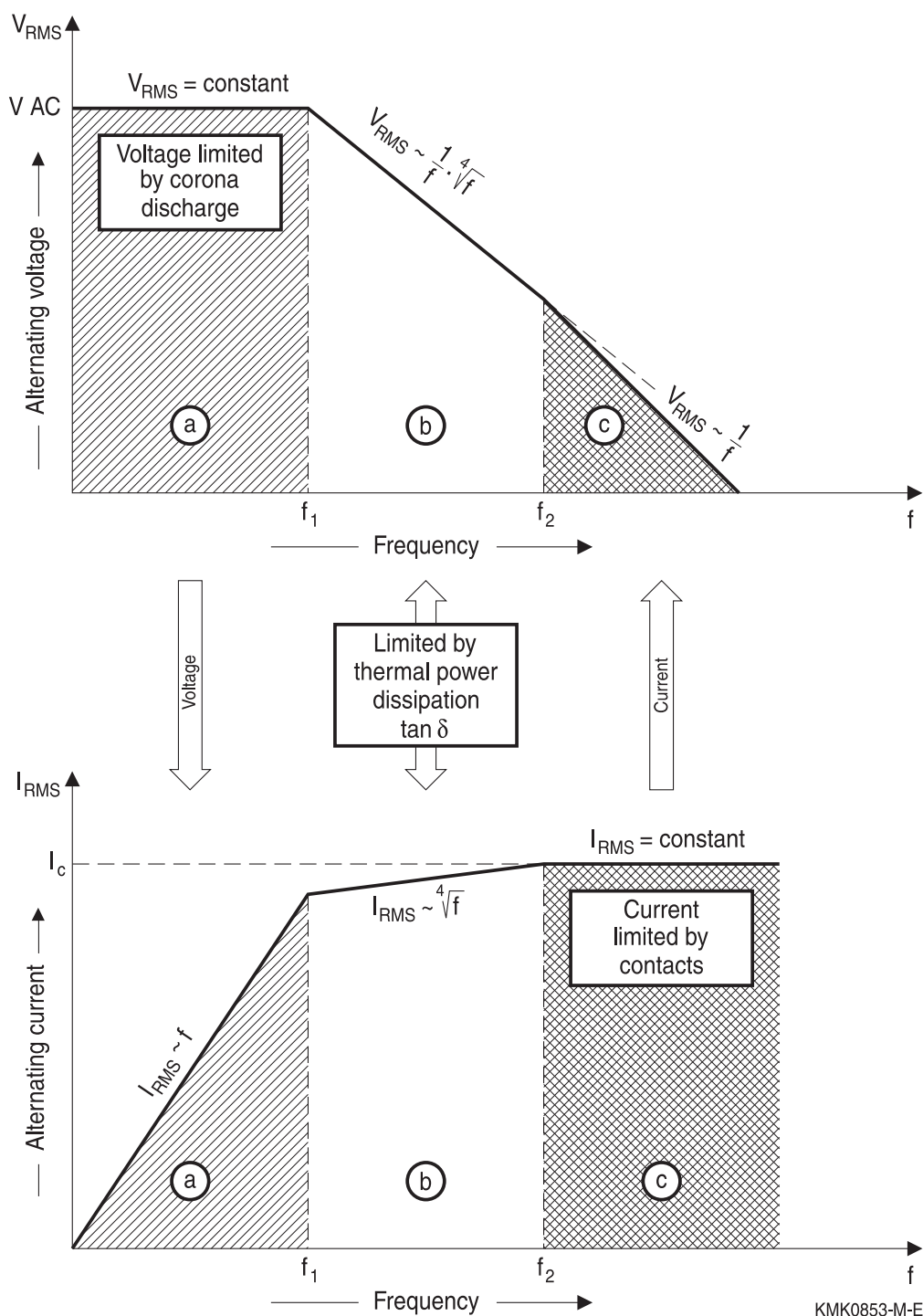

Figure 22
Alternating voltage and alternating current load limits

General technical information

Region (a): Limit at which corona discharge starts to occur V_{CD}

Below a certain frequency limit f_1 the applied AC voltage V_{RMS} should not exceed the threshold voltage V_{CD} at which corona discharge would start to occur with some intensity in air pockets in the capacitor (refer to section 6.2). It may degrade the film metallization and occasionally endanger its dielectric strength. For sinusoidal waveforms, the following relation must be taken into consideration:

$$V_{RMS} \leq V_{CD} \quad \text{or} \quad I_{RMS} \leq V_{CD} \cdot 2\pi f \cdot C$$

For non-sinusoidal waveforms

$$V_{pp} \leq 2 \cdot \sqrt{2} \cdot V_{CD}$$

Region (b): Limit due to thermal power dissipation

Above a certain frequency limit f_1 the permissible alternating voltage load must be reduced with increasing frequency to keep the power generated in the capacitor body (P_{gen}) below the power that can be dissipated by the surface of the capacitor (P_{diss}):

$$P_{gen} \leq P_{diss}$$

The two powers are defined as:

$$P_{gen} = V_{RMS}^2 \cdot 2\pi f \cdot C \cdot \tan \delta$$

$$P_{diss} = \alpha \cdot A \cdot \Delta T$$

α = Heat transfer coefficient

ΔT = Self-heating or steady-state overtemperature attained at the hottest part of the capacitor surface in relation to the surrounding atmosphere.

A = Surface area of the capacitor

To prevent permanent damage to the capacitor, the self-heating ΔT must not exceed a certain value, depending on the dielectric material:

Dielectric	max. ΔT
Polyester (PET), Polyethylene naphthalate (PEN)	15 °C
Polypropylene (PP)	10 °C

General technical information

Since $P_{\text{gen}} \leq P_{\text{diss}}$, the conditions for the maximum permissible alternating voltages and alternating currents in this region can be deduced as:

$$V_{\text{RMS}} \leq \sqrt{\frac{\alpha \cdot A \cdot \Delta T}{2\pi f \cdot C \cdot \tan \delta}} \quad \text{or} \quad I_{\text{RMS}} \leq \sqrt{\frac{2\pi f \cdot C \cdot \alpha \cdot A \cdot \Delta T}{\tan \delta}}$$

Their frequency dependency can be approximated by

$$V_{\text{RMS,max}} \sim \frac{1}{f} \cdot \sqrt[4]{f} \quad \text{or} \quad V_{\text{RMS,max}} \sim \sqrt[4]{f}$$

The heat transfer coefficient α and the dissipation factor $\tan \delta$ depend on technology, construction, material and geometry of each capacitor; $\tan \delta$ also depends on frequency and temperature. This complicates the use of these equations to calculate the maximum allowed V_{RMS} or the self-heating (ΔT) under practical operating conditions. The limit lines for the maximum V_{RMS} at moderate temperatures have consequently been obtained empirically and are illustrated in the data sheets relative to each series. A generic example is provided:

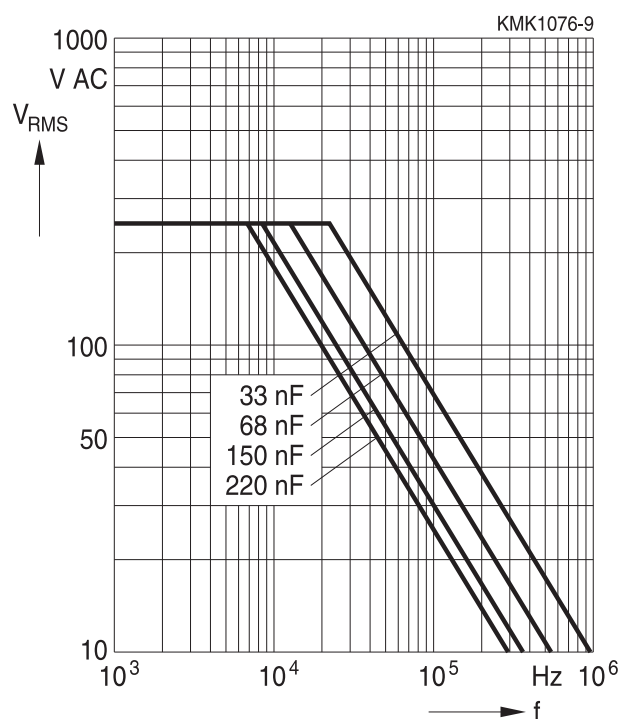

Figure 23
Example of maximum allowed V_{RMS} vs. frequency f for sinusoidal waveform

Figure 23 shows that a 220 nF capacitor has a maximum V_{RMS} of 100 V at 20 kHz. So under these conditions (100 V_{RMS} , 20 kHz), if the dielectric is PP, the self-heating (ΔT) will be 10 °C. If the dielectric is PET or PEN, the self-heating will be 15 °C.

Now to calculate the maximum I_{RMS} at this frequency:

$$I_{\text{RMS}} = V_{\text{RMS}} \cdot 2\pi f \cdot C = 100 \cdot 2\pi \cdot 20000 \cdot 220 \cdot 10^{-9} = 2.765 \text{ A}$$

General technical information

For intermediate values of capacitance not included in the graphs, for example $C' = 200$ nF, the permissible RMS voltage or current can be approximately calculated from the closest existing curves according to:

$$V'_{\text{RMS}} = V_{\text{RMS}} \cdot \sqrt{\frac{C}{C'}} = 100 \cdot \sqrt{\frac{220}{200}} = 104.8 \text{ V}$$

$$I'_{\text{RMS}} = I_{\text{RMS}} \cdot \sqrt{\frac{C'}{C}} = 2.765 \cdot \sqrt{\frac{200}{220}} = 2.636 \text{ A}$$

Sometimes it is necessary to estimate the self-heating $\Delta T'$ for a given V'_{RMS} (i.e. 75 V) and frequency (i.e. 20 kHz). From each curve in the corresponding datasheet we can obtain the maximum allowed $V_{\text{RMS,max}}$ at the required frequency. In this example, it is 100 V at 20 kHz. The following equations are applied:

$$\Delta T_{V',f} = \left(\frac{V'_{\text{RMS}}}{V_{\text{RMS,max}}} \right)^2 \cdot \Delta T_{V,f} = \left(\frac{75}{100} \right)^2 \cdot 15 = 8.4 \text{ }^\circ\text{C for PET or PEN dielectric}$$

$$\Delta T_{V',f} = \left(\frac{V'_{\text{RMS}}}{V_{\text{RMS}}} \right)^2 \cdot \Delta T_{V,f} = \left(\frac{75}{100} \right)^2 \cdot 10 = 5.6 \text{ }^\circ\text{C for PP dielectric}$$

The former calculations correspond to pure sinusoidal waveforms. Usually, practical applications will not involve loads with perfect sine-wave functions. In some common applications, however, it is possible to estimate the loads accurately enough by approximating them to sine-waves, as in the cases shown in figure 24. In other cases, the power dissipation must be calculated by Fourier decomposition of the waveform into its harmonics:

$$P_{\text{gen}} = \sum V_{\text{RMS},i}^2 \cdot 2\pi f_i \cdot C \cdot \tan \delta(f_i)$$

And so a theoretical overtemperature ΔT can be calculated equating $P_{\text{gen}} = P_{\text{diss}}$. If we are to assist in such cases, please send us scaled oscillograms.

General technical information

Waveform

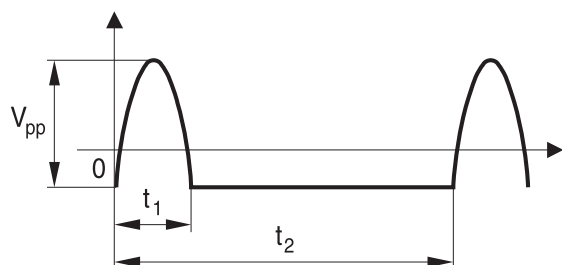

Electrical parameters

$$V_{RMS} = 1.07 \cdot \frac{V_{pp}}{\sqrt{2 \cdot N}}$$

$$N = \frac{t_2}{t_1}$$

$$f = \frac{1}{2 \cdot t_1}$$

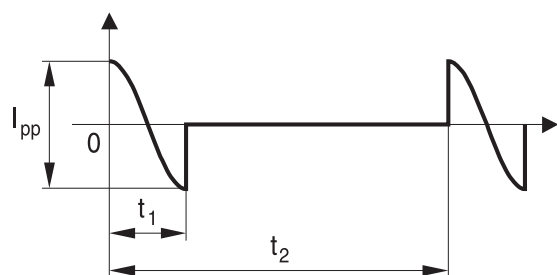

KMK0813-T-E

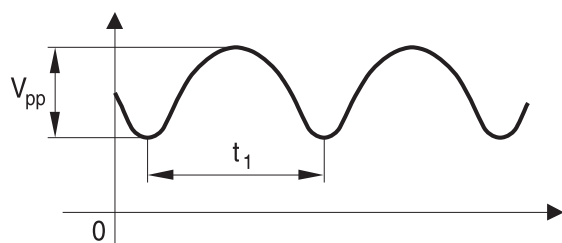

$$V_{RMS} = \frac{V_{pp}}{2 \cdot \sqrt{2}}$$

$$f = \frac{1}{t_1}$$

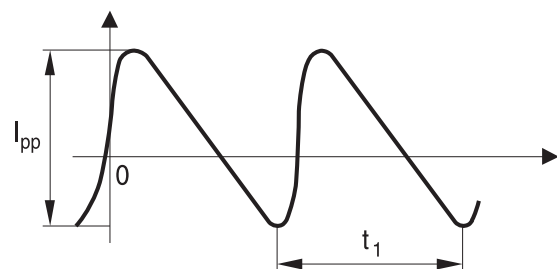

KMK0814-2-E

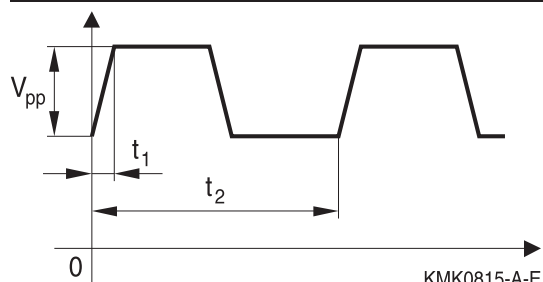

KMK0815-A-E

$$V_{RMS} = V_{pp} \cdot \sqrt{\frac{3t_2 - 4t_1}{12t_2}}$$

$$f = \frac{1}{t_2}$$

Figure 24

V_{RMS} approximation for non-sinusoidal waveforms

General technical information

Region (c): Limit due to maximum current handling capability

Above another frequency limit f_2 , the permissible AC voltage load is limited by the maximum current I_C that can pass through the connection between sprayed metal and film metallization, without causing overheating due to associated resistive losses:

$$V_{\text{RMS}} \leq \frac{I_C}{2\pi f \cdot C} \quad \text{or} \quad I_{\text{RMS}} \leq I_C$$

In practice however, this region is only evident for small capacitances with short contact lengths.

Note

Even if the graphs shown for the AC load capability of capacitors cover the line voltage range, standard film capacitors are basically not suitable for operation directly connected to public power networks. In this context, we would refer you the EMI suppression capacitors, which are specially designed for power line applications (refer to chapter "EMI suppression capacitors").

3.2.3 Maximum AC voltage versus temperature

The graphs described in the previous section for the maximum AC voltage vs. frequency are valid for moderate temperatures: $T_A \leq 55^\circ\text{C}$ in MKT and $T_A \leq 90^\circ\text{C}$ in MKP/MFP. For temperatures higher than these limits, we have to consider additional effects depending on the frequency and dielectric:

Low frequencies ($f < f_1$)

For frequencies below f_1 (i.e. in region (a) of figure 22), a derating of the V_{RMS} versus the working temperature has to be applied, following the rules defined in 3.1.3.

High frequencies ($f \geq f_1$)

For frequencies above f_1 (i.e. regions (b) and (c) of figure 22), taking into account that the operating temperature of a capacitor is the sum of the ambient temperature and the self-heating:

$$T_{\text{op}} = T_A + \Delta T$$

we must assure that the operating temperature does not exceed the upper category temperature

$$T_{\text{max}}$$

$$T_{\text{op}} \leq T_{\text{max}}$$

General technical information

- In **MKP** and **MFP**, this is assured by derating the V_{RMS} obtained in the graphs by a derating factor F_T :

$$V_{RMS}(T_A > 90\text{ °C}) = V_{RMS}(T_A \leq 90\text{ °C}) \cdot F_T$$

F_T has been defined empirically as per figure 25.

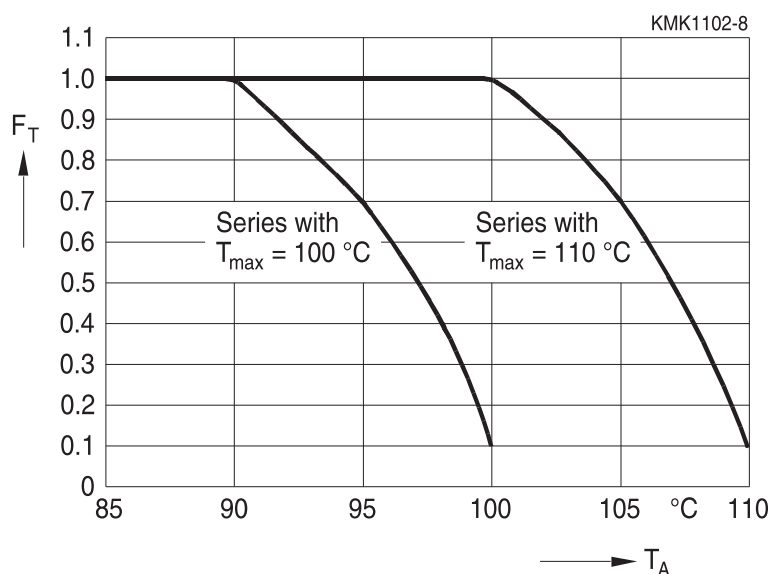

Figure 25
Derating factor F_T for MKP and MFP capacitors vs. ambient temperature T_A

- In **MKT**, since $\tan \delta$ increases with temperature (as seen in figure 16) there is a temperature dependence in P_{gen} and thus in the equilibrium points obtained from $P_{gen} = P_{diss}$. Therefore the maximum V_{RMS} cannot be directly extrapolated by derating the graphs obtained for lower temperatures. In these cases a theoretical calculation can be carried out by EPCOS engineers.
- For any critical case in both dielectrics, a temperature check on the capacitor under working conditions should be carried out. The test fixture should be as shown in figure 26: a dummy capacitor with similar size as the capacitor under test is used to measure the ambient temperature (the points for measuring temperature are marked with "X").

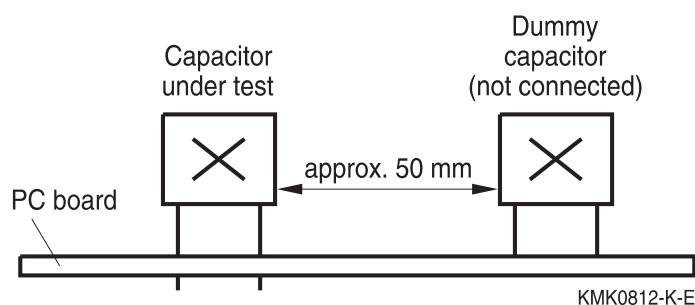

Figure 26
Test fixture for measurement of self-heating under working conditions

3.3 Pulse withstanding

Voltage pulses with rapid voltage changes will lead to strong peak currents in a capacitor. These currents will generate heat in the contact regions between the sprayed metal and the film metalization. Thus there is a limit to the pulse that can be applied to a particular capacitor when the heat dissipated is high enough to damage these regions.

The parameters that define the pulse handling capability of a capacitor are the maximum dV/dt and k_0 it can withstand.

3.3.1 Voltage pulse slope dV/dt

If only the peak current i_p associated with a voltage pulse is considered, the maximum voltage pulse slope dV/dt of a pulse can be defined as:

$$\frac{dV}{dt} = \frac{i_p}{C}$$

Values of maximum dV/dt are given in the data sheets of the individual types. Units are $V/\mu s$.

3.3.2 Pulse characteristic k_0

The heat energy Q generated by a pulse in the capacitor can be calculated from:

$$Q = \int_0^\tau i^2 \cdot R_i \cdot dt = \int_0^\tau C^2 \left(\frac{dV}{dt} \right)^2 \cdot R_i \cdot dt$$

where τ is the pulse width and R_i the resistance of the contacts (internal resistance). To relate the heat energy and the pulse slope, a characteristic factor k_0 depending on the waveform can be defined:

$$k_0 = 2 \cdot \int_0^\tau \left(\frac{dV}{dt} \right)^2 \cdot dt$$

The k_0 value of a particular waveform should not exceed the maximum permissible values given in the data sheets of each capacitor series. Units are $V^2/\mu s$.

k_0 values are valid on assumption of complete dissipation of heat between consecutive pulses, which is the case for duty cycles higher than 100 μs . For lower duty cycles (i.e. for repetition frequencies higher than 10 kHz), heat dissipation from pulse to pulse is not complete, and a dangerous overheating builds up that might destroy the capacitor. In these cases, a derating of the permissible k_0 value should be applied.

Digital oscilloscopes allow direct calculation of the k_0 value of a waveform. However, there are two cases in which k_0 can be calculated analytically:

- Ramp discharge
- Passive discharge

3.3.3 Pulse approximation for simple discharges

Ramp discharge

When the capacitor is discharged from a particular voltage to zero in a single ramp (see figure 27), the voltage pulse slope can be approximated by:

$$\frac{dV}{dt} \approx \frac{V_{pp}}{\tau}$$

V_{pp} : Peak-to-peak voltage
 τ : Voltage decay time

On the other hand, k_0 can be calculated by a piecewise linear decomposition, comprising $\Delta V - \Delta t$ segments:

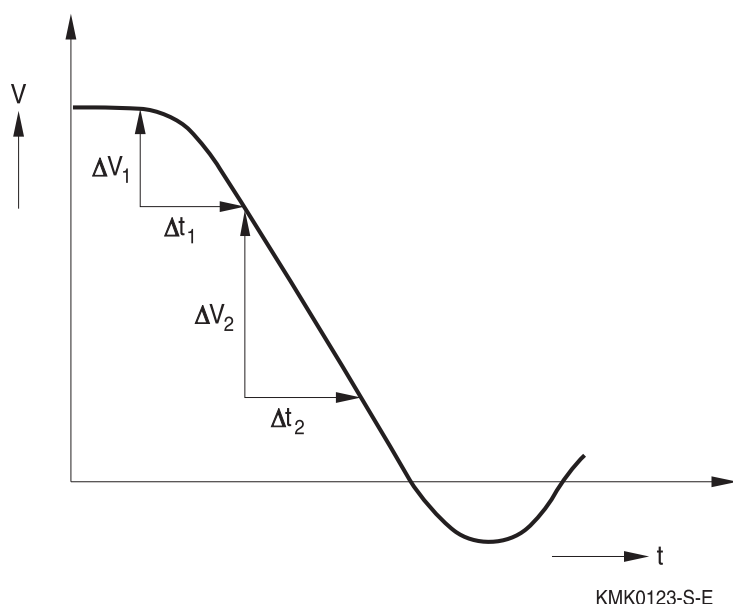

Figure 27
 Piecewise linear approximation of a voltage pulse

$$k_0 \approx 2 \cdot \left(\Delta V_1 \cdot \frac{\Delta V_1}{\Delta t_1} + \Delta V_2 \cdot \frac{\Delta V_2}{\Delta t_2} + \dots \right)$$

A simpler approximation (exact for trapezoidal or sawtooth pulses) can be obtained by:

$$k_0 \cong 2 \cdot \frac{V_{pp}^2}{\tau}$$

and thus

$$\frac{dV}{dt} \cong \frac{V_{pp}}{\tau} = \frac{k_0}{2 \cdot V_{pp}}$$

As an example, take an MKT stacked-film capacitor B32520 / Lead spacing = 7.5 / $V_R = 250$ V DC:

$$k_0 = 100000 \text{ V}^2/\mu\text{s}$$

$$dV/dt = 200 \text{ V}/\mu\text{s}$$

General technical information

For discharge from the full rated voltage ($V_{pp} = V_R$):

$$\frac{dV}{dt} = \frac{V_{pp}}{\tau} = \frac{k_0}{2 \cdot V_{pp}} = \frac{100000 \text{ V}^2/\mu\text{s}}{2 \cdot 250 \text{ V}} = 200 \text{ V}/\mu\text{s}$$

while discharge from a lower peak-to-peak voltage of e.g. 100 V DC produces:

$$\frac{dV}{dt} = \frac{V_{pp}}{\tau} = \frac{k_0}{2 \cdot V_{pp}} = \frac{100000 \text{ V}^2/\mu\text{s}}{2 \cdot 100 \text{ V}} = 500 \text{ V}/\mu\text{s}$$

meaning that for a lower voltage a higher current peak can be allowed because the pulse duration is shorter and the thermal load (i.e. the pulse characteristic k_0) is equivalent. Therefore, dV/dt data are defined for discharge from the rated voltage ($V_{pp} = V_R$). For discharge voltages other than V_R , dV/dt can be calculated by multiplying the value in the data sheet by V_R/V_{pp} .

Passive discharge

For discharging in passive (RLC) and short-circuit configurations, there is no simple approximation for dV/dt , which has to be obtained from I_p :

$$\frac{dV}{dt} = \frac{i_p}{C}$$

k_0 is exactly determined by

$$k_0 = \frac{V_{ch}^2}{R \cdot C}$$

V_{ch} : Charging voltage

R : Ohmic resistance of discharge circuit

3.3.4 Pulse withstanding vs. construction

The pulse handling capability of a capacitor is determined, in particular, by the internal structure of the capacitor element. Construction variants are shown in sections 1.2 and 1.3.

Apart from the layer structure variants, stacked-film capacitors have basic advantages over wound capacitors in terms of pulse-handling capabilities. Since, in principle, a stacked-film capacitor comprises a large number of independent capacitors in parallel, any contact weakness occurring can only affect individual capacitor elements, not extending to neighboring ones, and thus limiting damage to a minor loss of capacitance.

3.4 EMI suppression

Refer to chapter "EMI suppression capacitors" of this data book.

General technical information

4 Climatic stress

4.1 Climatic category

The climatic category is identified by 3 groups of figures, separated by slashes, as specified in IEC 60068-1:2013, Appendix A.

Example: 55 / 100 / 56

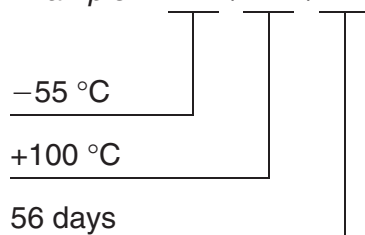

■ 1st group of figures

Absolute value of the lower category temperature T_{\min} . It is the minimum ambient temperature for which a capacitor is designed to operate continuously. T_{\min} is also the temperature for test Aa (cold) to IEC 60068-2-1:2007.

■ 2nd group of figures

Upper category temperature T_{\max} . It is the maximum ambient temperature for which a capacitor is designed to operate continuously. T_{\max} is also the temperature for test Ba (dry heat) to IEC 60068-2-2:2007. The test duration is 16 h.

Note

When using a capacitor in AC applications, the associated self-heating will raise its surface temperature above the ambient temperature. It is essential to take this into account in order not to exceed the upper category temperature. A temperature check on a capacitor should be performed in case of doubt.

■ 3rd group of figures

Duration in days of test Ca (damp heat, steady state) to IEC 60068-2-3:1969. The test conditions are (93 +2/-3) % rel. humidity and 40 °C ambient temperature. The limit values permissible after the damp heat test are given in the data sheets for the respective capacitor types.

4.2 Effect of temperature

The **reversible effects** of temperature on capacitance, dissipation factor and insulation resistance are treated in the respective sections.

Excessive exposure to temperatures higher than T_{\max} will cause thermal aging of the film following Arrhenius' law, which will produce **irreversible effects** on electrical characteristics. Additional changes in the capacitor dimensions will follow as a consequence of film shrinkage.

General technical information

4.3 Effect of humidity

The absorption of moisture increases the number of permanent dipoles inside the capacitor, producing **reversible effects** on capacitance, dissipation factor and insulation resistance, which are treated in the respective sections. These occur for relative humidity less than 93%, applied for a limited time, and can be reversed by a drying process.

The equilibrium data provided for the reversible changes are independent of the construction and finish of the film capacitor: there will only be differences in the rate of moisture absorption/desorption, which will depend on:

- Capacitor finish: Humidity penetrates faster into uncoated components (and also diffuses out faster)
- Ambient temperature and humidity

Typical values of the time constants for absorption/desorption vary between half a day (e.g. uncoated capacitors) and several weeks (e.g. capacitors with plastic cases).

Long contact of a film capacitor with humidity will produce **irreversible effects**. Direct contact with liquid water (especially for uncoated components) or excess exposure to high ambient humidity or dew will eventually remove the film metallization and thus destroy the capacitor.

Simulations of the effect of humidity are done through the humidity test defined in the climatic category. Accelerated testing can be performed under more severe conditions, if the relative severities are taken into account. The severity S of any humidity test can be defined as the product of two factors

$$S = \rho \cdot F_D$$

where

ρ Density of water vapor in air, which is a function of both relative humidity and temperature: these data can be extracted from standardized psychrometric charts (e.g. $\rho = 47 \text{ gr/m}^3$ for $T = 40 \text{ }^\circ\text{C}$ and humidity = 93%)

F_D Thermal acceleration factor for diffusion (acc. to Arrhenius' law):

$$F_D = \text{EXP}(-E/RT)$$

E Activation energy for diffusion = $1.0\text{E}4 \text{ cal/mol}$

R Universal molar constant for gases = 1.987 cal/mol K

T Temperature in kelvins = $T \text{ (in } ^\circ\text{C)} + 273$

The test severity S helps to compare the conditions of humidity tests. As an example, in the following table the data for some common test conditions are compared and referred to the standard conditions ($40 \text{ }^\circ\text{C}/93\%$, $S' = 1$).

Temperature ($^\circ\text{C}$)	Humidity (%)	ρ (gr/m^3)	S	S'
40	93	47	$4.89\text{E}-6$	1.0
65	95	151	$5.14\text{E}-5$	10.5
85	85	294	$2.31\text{E}-4$	47.3

General technical information

4.4 Effect of low air pressure

As the atmospheric pressure drops, the risk of a flashover between capacitor terminations increases. Capacitors can be used at pressures down to 40 kPa without voltage derating being necessary. This corresponds to an altitude of 7000 m (approx. 23000 ft) above mean sea level. Capacitors for use at altitudes above 7000 m can be developed on special request.

Heat transfer can be affected by high altitude operation. Heat generated on the lead terminations cannot be dissipated properly and can result in overheating and eventual failure.

Film capacitors can also be affected by internal stresses due to pressure changes. This can take the form of capacitance changes as well as low insulation resistance.

4.5 Storage conditions

All capacitors listed in this data book can be stored at any temperature within the entire category temperature range for short periods. For long storage periods, however, the following conditions should be observed:

- Storage temperature -40 to $+40$ °C,
- Maximum relative humidity 80%, no dew allowed on the capacitor
- Maximum duration 5 years

5 Mechanical tests

5.1 Lead robustness

The mechanical robustness of the leads is tested to IEC 60068-2-21:2006.

Tensile strength (test Ua1)	Wire diameter d_1 in mm	Tensile force
	$0.3 < d_1 \leq 0.5$	5 N
	$0.5 < d_1 \leq 0.8$	10 N
Bending strength (test Ub)	$0.8 < d_1 \leq 1.25$	20 N
	Procedure 1: Two consecutive bends by 90° , in opposite directions	
	Wire diameter d_1 in mm	Bending force
Torsional strength (test Uc)	$0.3 < d_1 \leq 0.5$	2.5 N
	$0.5 < d_1 \leq 0.8$	5 N
	$0.8 < d_1 \leq 1.25$	10 N
Torsional strength (test Uc)	Procedure A, severity 2: Two successive rotations of 180° each	

Tests Ub and Uc are only carried out on types with axial wire leads.

General technical information

5.2 Resistance to vibration

A capacitor's ability to withstand vibration (e.g. as occurs in applications involving rotating machinery), is tested to IEC60068-2-6:2007.

The test procedure used here involves continuous vibration with continuously varying frequency and the following severities:

Test Fc: vibration, sinusoidal	Test conditions
Amplitude of displacement (below 57.6 Hz transition frequency)	0.75 mm
Amplitude of acceleration (above 57.6 Hz transition frequency)	98 m/s ² (\triangleq 10 g)
Frequency range	10 Hz ... 500 Hz
Test duration (in 3 orthogonal axes)	3 · 120 min

EPCOS offers film capacitors especially designed for operation under more severe vibration regimes, such as those found in automotive applications. Further information available upon request.

Specific mounting conditions:

- For smaller lead spaces than 22.5 mm, the capacitor shall be mechanically fixed by the leads.
- For lead spaces \geq 22.5 mm, the capacitor shall be fixed by the leads and the body must be properly clamped.

5.3 Flammability

5.3.1 Passive flammability

The passive flammability test is applied to ensure that components bearing the corresponding qualification contribute less energy to the combustion behavior of their immediate vicinity than is required to ignite them. This measure is meant to contain any localized fire that may occur.

In the respective tests, capacitors are subjected to a standardized flame to evaluate the combustion behavior by checking whether the flame persists longer than a maximum permissible period or not. The test severity is essentially determined by the test flame and the exposure time. In principle, the smaller the capacitor, the more easily flammable it is. The following tests are used:

Specifications	Flame height mm	Severity: time of exposure to flame s	Flame persistence s
UL1414:2000 9. Enclosure Test	19	Three-stage flame test: 1st period: 15 2nd period: 15 3rd period: 15	15 15 60
IEC 60695-2-2:1991	12 \pm 1	Preferred values: 5, 10, 20, 30, 60, 120	30

General technical information

Specifications	Flame height	Severity: time of exposure to flame				Flame persistence	
IEC 60384-14:2013 UL 60384-14:2014	12 ±1	Capacitor volume (mm ³)					
		≤250	>250	>500	>1750		
Category A		15	30	60	120		3
Category B		10	20	30	60		10
Category C		5	10	20	30	30	

Unless the detail specifications specify otherwise, EMI suppression capacitors are tested to IEC 60384-14:2013, section 4.17, test severity category B and C.

5.3.2 Active flammability

This test is applied exclusively to EMI suppression capacitors. Refer to chapter "EMI suppression capacitors".

5.3.3 Flammability of materials

In some cases, specifications regarding the flammability of materials in accordance with UL 94 are requested in addition to the results of capacitor flammability tests. UL 94 safety standards describe a material test carried out on test specimens for classifying the flammability of plastics. In the test according to UL 94 V, the test specimens (length 127 mm / 5", 12.7 mm / 0.5") are arranged vertically and exposed to a flame twice; they are then classified into flammability categories:

Flammability category	UL 94 V-0	UL 94 V-1	UL 94 V-2
Material burning persistence (s):			
Individual flame exposure	≤ 10	≤ 30	≤ 30
Total of 10 flame exposures (5 specimens)	≤ 50	≤ 250	≤ 250
Ignition of supporting layer by dropping burning particles	Not permitted	Not permitted	Permitted

The thickness of the test specimens must always be stated to enable evaluation of the flammability category, e.g.: UL 94 V-0 (3.2 mm) does not imply that the material will also comply with UL 94 V-1 (1.6 mm).

The sole object of UL 94 is to enable comparison of the relative flammability of various materials. It does not provide any information on the actual combustion characteristics of a capacitor.

6 Safety characteristics

6.1 Self-healing

The most important reliability feature of film capacitors is their self-healing capability, i.e. their ability to clear faults (such as pores or impurities in the film) under the influence of a voltage.

The metal coatings, vacuum-deposited directly onto the plastic film, are only 20 ... 50 nm thick. If the dielectric breakdown field strength is exceeded locally at a weak point, a dielectric breakdown occurs. In the breakdown channel, the high temperatures reached (up to 6000 K) transform the dielectric into a highly compressed plasma that forces its way out. The thin metal coating in the vicinity of the channel is totally evaporated by interaction with the plasma, retreating from the breakdown channel. The rapid expansion of the plasma causes it to cool after a few microseconds, thus quenching the discharge before a greater loss of voltage takes place. The insulated region thus resulting around the former faulty area will cause the capacitor to regain its full operation ability.

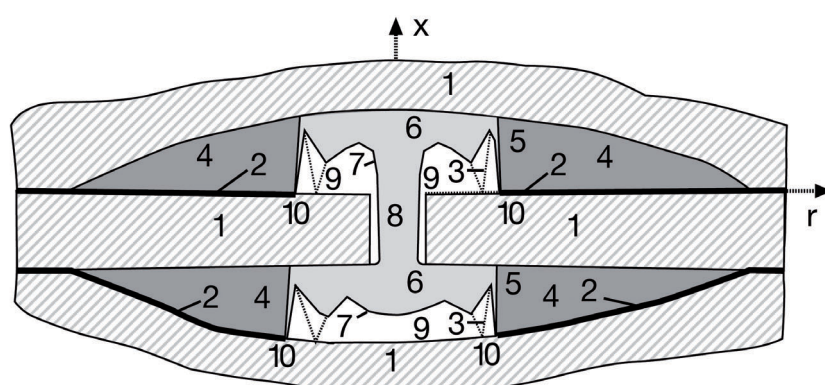

Figure 28

Schematic of the self-healing area during electrical breakdown

- 1 Dielectric
- 2 Metallized electrodes
- 3 Material displacing shock wave
- 4 Air gap with metal vapor
- 5, 6 Plasma zone
- 7 Boundary layer between gas phase dielectric and plasma
- 8 Breakdown channel
- 9 Gas phase dielectric
- 10 Zone of displaced metallization and dielectric (insulating region)

Note

At low voltages, anodic oxidation of the metal coatings leads to an electrochemical self-healing process.

6.2 Corona discharges

The air inside the microgaps that are normally present in and around the capacitor (e.g. inside and between the films, near the corners) may get ionized, leading to a destructive process called corona effect.

This occurs when the intensity of the electric field in the capacitor exceeds the dielectric rigidity of the air. In these conditions, small corona discharges take place, producing two undesirable effects:

- Removal of the film metallization edges, and thus drop of capacitance.
- Occasionally, structural damages caused by the bombardment of the film with ions and electrons might occur as well. This produces a reduction of the breakdown voltage level of the dielectric, and eventually might give rise to a short-circuit or fire.

The voltage at which this phenomenon starts is called corona starting voltage V_{CD} . Its value is determined, above all, by the internal construction of the capacitors (which determines the field strength at the edges); it also depends, to a lesser extent, on the thickness of the dielectric. This voltage limit can be raised, in particular, by using internal series connection designs. However, if a capacitor is used below V_{CD} , no corona effect will be observed and the corresponding degradation can be neglected (see section 3.2.2).

6.3 Dielectric absorption

If a capacitor that has remained charged for a long period of time is submitted to a brief discharge in short-circuit, within seconds or minutes the voltage on the capacitor will tend to recover to a fixed percentage of its original value (typically between 0.01% and 2%). This effect is known as dielectric absorption. The recharging comes from polarization processes in the dielectric material, and is largely independent of the capacitance of a capacitor and the thickness of its dielectric.

The phenomenon has a particularly unfavorable effect in sample and hold applications, in which charges are to be stored for comparison or measuring purposes. Measurements of dielectric absorption are performed to IEC 60384-1:2016.

Typical values:

Dielectric		PP	PET	PEN
Dielectric absorption	%	0.05	0.2	1.2

6.4 Buzz noise

Under AC regime, buzzing noise is produced in film capacitors by the mechanical vibration of the films, due to the Coulomb force existing between electrodes of opposite polarity. Buzz noise becomes louder if the applied voltage waveform presents distortion and/or high frequency harmonics.

Buzz noise does not affect the capacitor structure, nor its electrical characteristics or reliability.

6.5 Cracks (SilverCaps only)

During the fabrication process of stacked-film capacitors, the single layers of metallized film are faced with mechanical strains during the winding, scooping, tempering and sawing of the capacitor. Furthermore, during the soldering process, the local heating-up of a capacitor might force a quick evacuation of the humidity stored between the film layers, producing a similar strain. All these mechanical strains may be released naturally by cracks, which mainly occur at the bottom side of the capacitors, between the leads.

Intense endurance tests of such components have proven that cracks have no influence on the electrical properties or the reliability of the uncoated capacitors (SilverCap), so the occurrence of such cracks is not dangerous for the application.