



Aluminum Electrolytic Capacitors

Snap-in Capacitors

Series/Type: B43662
Status: In development

Date: July 2026

Preliminary data

Important information

This series is not yet released for mass production and subject to change. The products delivered are engineering samples, prototypes or pre-series products, which are not intended for commercial use in series products of the purchaser. The supplier assumes no warranty or liability. Any use is at the sole risk of the purchaser.

General-purpose grade capacitors
Applications

- Power supplies
- Frequency converters
- Uninterruptible power supplies
- Solar inverters
- Not for automotive applications unless otherwise specified

Features

- Ultra-compact
- High reliability
- High ripple current capability
- RoHS-compatible

Construction

- Minus pole marking on shrinking sleeve
- Minus pole not insulated from case
- Overload protection by pressure relief device on the base

Terminals

- Snap-in terminals (2 pins, 4.5 mm)
- Snap-in terminals (2 pins, 6.3 mm)
- Snap-in terminals (3 pins, 4.5 mm)



Preliminary data
Specifications and characteristics in brief

Rated voltage V_R Surge voltage V_S	450 ... 475 V DC $1.10 \cdot V_R$ (15 ... 35 °C)										
Rated capacitance C_R Capacitance tolerance	$\pm 20\% \triangleq M$										
Dissipation factor $\tan \delta$ ($T_A = 20$ °C, 120 Hz)	≤ 0.25										
Leakage current I_{leak} (5 min, $T_A = 20$ °C, reforming before measurement)	$I_{leak} \leq 0.3 \mu A \cdot \left(\frac{C_R}{\mu F} \cdot \frac{V_R}{V} \right)^{0.7} + 4 \mu A$										
Self-inductance ESL	Approx. 20 nH										
Useful life ¹⁾ $T_A = 105$ °C; V_R ; $I_{AC,R}$	> 5000 h	Requirements: $ \Delta C/C \leq 20\%$ of initial value $\tan \delta \leq 2$ times initial specified limit $I_{leak} \leq$ initial specified limit									
Vibration resistance test	To IEC 60068-2-6:2007, test Fc: Frequency range 10 ... 55 Hz, displacement amplitude 0.35 mm, acceleration max. 5 g, duration 3×2 h. Capacitor mounted by its body which is rigidly clamped to the work surface.										
Characteristics at low temperature	<table border="1"> <tr> <td>Max. impedance ratio at 100 Hz</td> <td>V_R</td> <td>450 ... 475 V</td> </tr> <tr> <td></td> <td>$Z_{T_A=-25\text{ °C}} / Z_{T_A=20\text{ °C}}$</td> <td>10</td> </tr> <tr> <td></td> <td>$Z_{T_A=-40\text{ °C}} / Z_{T_A=20\text{ °C}}$</td> <td>20</td> </tr> </table>		Max. impedance ratio at 100 Hz	V_R	450 ... 475 V		$Z_{T_A=-25\text{ °C}} / Z_{T_A=20\text{ °C}}$	10		$Z_{T_A=-40\text{ °C}} / Z_{T_A=20\text{ °C}}$	20
Max. impedance ratio at 100 Hz	V_R	450 ... 475 V									
	$Z_{T_A=-25\text{ °C}} / Z_{T_A=20\text{ °C}}$	10									
	$Z_{T_A=-40\text{ °C}} / Z_{T_A=20\text{ °C}}$	20									
IEC climatic category	To IEC 60068-1:2013: 25/105/56 (–25 °C/+105 °C/56 days damp heat test): The capacitors can be operated in the temperature range of $T_A = -40$ °C to $T_A = +105$ °C but the impedance at –40 °C must be taken into consideration.										
Sectional specification ²⁾	IEC 60384-4:2016										

1) Refer to chapter "General technical information, 5 Useful life" on how to interpret useful life.

2) Refer to chapter "General technical information, 2 Standards and specifications" for further details.

Preliminary data

Dimensional drawings

Snap-in capacitors with PET sleeve, without base disk

“PET” marking on the sleeve. Pressure relief device on the base.

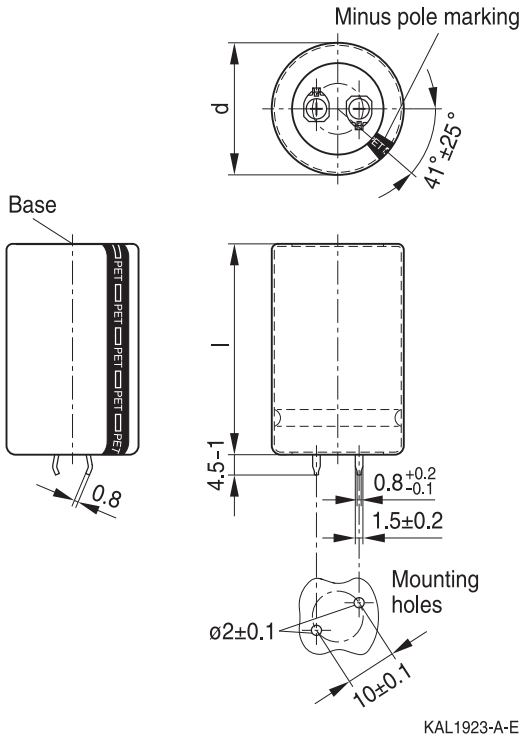

KAL1923-A-E

Snap-in terminals (2 pins, 4.5 mm)

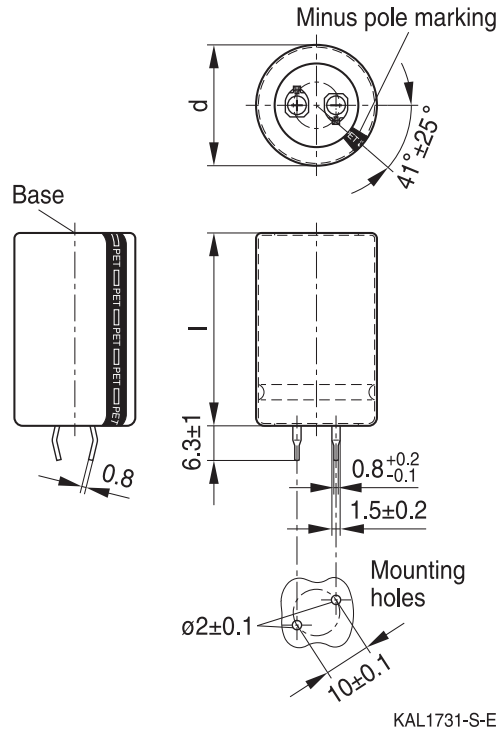

KAL1731-S-E

Snap-in terminals (2 pins, 6.3 mm)

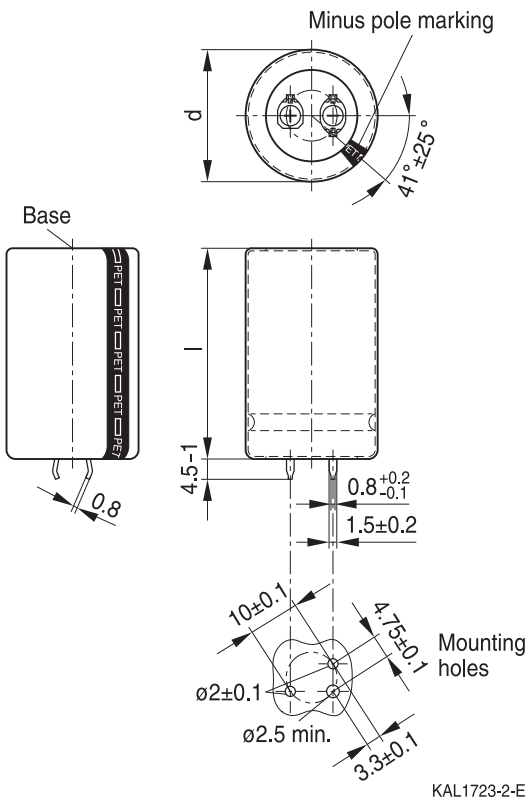

KAL1723-2-E

Snap-in terminals (3 pins, 4.5 mm)

Preliminary data
Dimensions and packing units

Dimensions (mm)		Approx. weight (g)	Packing units (pcs.)
d +1	l +2.5/-2		
22	25	9	160
22	30	12	160
22	35	15	160
22	40	18	160
22	45	20	160
22	50	24	160

Dimensions (mm)		Approx. weight (g)	Packing units (pcs.)
d +1	l +2.5/-2		
25.4	25	13	130
25.4	30	17	130
25.4	35	19	130
25.4	40	22	130
25.4	45	25	130
25.4	50	29	130
25.4	55	32	130
25.4	60	36	45
25.4	65	39	45
25.4	70	42	45
25.4	75	45	45
25.4	80	48	45

Dimensions (mm)		Approx. weight (g)	Packing units (pcs.)
d +1	l +2.5/-2		
30	25	17	80
30	30	23	80
30	35	29	80
30	40	36	80
30	45	41	80
30	50	46	80
30	55	53	80
30	60	58	60
30	65	64	60
30	70	69	60
30	75	74	60
30	80	80	60
30	85	86	60
30	90	92	60
30	95	98	60
30	100	103	60
30	105	109	60
30	110	115	60
30	115	120	60
30	120	126	60

Dimensions (mm)		Approx. weight (g)	Packing units (pcs.)
d +1	l +2.5/-2		
35	25	22	60
35	30	29	60
35	35	36	60
35	40	41	60
35	45	56	60
35	50	70	60
35	55	81	60
35	60	90	36
35	65	102	36
35	70	115	36
35	75	128	36
35	80	142	36
35	85	148	36
35	90	159	36
35	95	171	36
35	100	182	36
35	105	194	36
35	110	205	36
35	115	217	36
35	120	228	36

Preliminary data
Packaging of snap-in capacitors

For ecological reasons cardboard is used for packaging.

Ordering codes

Identification in 3rd block of ordering code

	PET sleeve, without base disk
Snap-in terminals (2 pins, 4.5 mm)	M*57
Snap-in terminals (3 pins, 4.5 mm)	M*52
Snap-in terminals (2 pins, 6.3 mm)	M*50

* Digit used for nominal capacitance indication.

Cautions and warnings

Personal safety

The electrolytes used have been optimized both with a view to the intended application and with regard to health and environmental compatibility.

As far as possible, we do not use any dangerous chemicals or compounds to produce operating electrolytes, although in exceptional cases, such materials must be used in order to achieve specific physical and electrical properties because no alternative materials are currently known.

We do, however, restrict the amount of dangerous materials used in our products to an absolute minimum.

Materials and chemicals used in our Aluminum Electrolytic Capacitors and Hybrid Polymer Capacitors are continuously adapted in compliance with the TDK Electronics Corporate Environmental Policy and the latest EU regulations and guidelines such as RoHS, REACH/SVHC, GADSL, and ELV.

MDS (Material Data Sheets) are available on our website for types listed on the product information site of TDK.

MDS for customer specific capacitors are available upon request.

Nevertheless, the following rules should be observed when handling Aluminum Electrolytic Capacitors and Hybrid Polymer Capacitors: No electrolyte should come into contact with eyes or skin. If electrolyte does come into contact with the skin, wash the affected areas immediately with running water. If the eyes are affected, rinse them for 10 minutes with plenty of water. If symptoms persist, seek medical treatment. Avoid inhaling electrolyte vapor or mists. Workplaces and other affected areas should be well ventilated. Clothing that has been contaminated by electrolyte must be changed and rinsed in water.

Product safety

The table below summarizes the safety instructions that must be observed without fail. A detailed description can be found in the relevant sections of separate file chapter “General technical information”.

Topic	Safety information	Reference chapter “General technical information”
Polarity	Make sure that polar capacitors are connected with the right polarity.	1 “Basic construction of aluminum electrolytic capacitors”
Reverse voltage	Voltages of opposite polarity should be prevented by connecting a diode.	3.1.6 “Reverse voltage”
Operating temperature range	Do not exceed the temperature limits specified in the product data sheet. Useful life and reliability depend to a large extent on the capacitor's temperature.	7.1, 7.2 “Minimum and maximum permissible operating temperatures”
Storage	Do not store capacitors at high temperatures or high humidity. Capacitors should be stored at +5 to +35 °C and a relative humidity of $\leq 75\%$.	7.3 “Shelf life and storage conditions”
Mounting of capacitors	The internal and external structure of capacitors might be damaged if excessive force is applied to their terminals. Avoid any compressive, tensile or flexural stress. Do not move the capacitor after soldering to PC board. Do not pick up the PC board by the soldered capacitor. Do not insert the capacitor on the PC board with a hole space different to the lead space specified.	11 “Mounting”
Mounting position of capacitors	The position of the pressure relief device must be taken into consideration when designing the application layout. As a rule, the function of the pressure relief device must not be impaired or blocked by the mounting. Screw terminal capacitors, with pressure relief device in the cover disk, must not be mounted with terminals facing down unless otherwise specified. Multi-pin capacitors with pressure relief device on the can base must not be mounted with terminals facing up unless otherwise specified.	11.1 “Mounting positions of capacitors”
Robustness of terminals	Unless otherwise specified, the following maximum tightening torques must not be exceeded when connecting screw terminals: M5: 2.5 Nm M6: 4.0 Nm	11.2 “Mounting torques”

Topic	Safety information	Reference chapter “General technical information”
Potting and gluing	If applied, potting and gluing materials must not impair the function of the capacitor’s pressure relief device.	11.4 “Potting and gluing”
Soldering	Do not exceed the specified time or temperature limits during soldering.	11.5 “Soldering”
Soldering, cleaning agents	Do not allow halogenated hydrocarbons to come into contact with Aluminum Electrolytic Capacitors or Hybrid Polymer Capacitors.	11.6 “Cleaning agents”
Passive flammability	Avoid external energy, e.g. fire.	8.1 “Passive flammability”
Active flammability	Avoid overload of the capacitors.	8.2 “Active flammability”
Maintenance	Make periodic inspections of the capacitors. Before the inspection, make sure that the power supply is turned off and carefully discharge the capacitors. Do not apply excessive mechanical stress to the capacitor terminals when mounting.	10 “Maintenance”
		Reference chapter “Capacitors with screw terminals”
Breakdown strength of shrinking sleeve	Do not damage the shrinking sleeve, especially when ring clips are used for mounting.	“Screw terminals – accessories”

Display of ordering codes for TDK Electronics products

The ordering code for one and the same product can be represented differently in data sheets, data books, other publications, on the company website, or in order-related documents such as shipping notes, order confirmations and product labels. The varying representations of the ordering codes are due to different processes employed and do not affect the specifications of the respective products.

Detailed information can be found on the Internet under www.tdk-electronics.tdk.com/orderingcodes.

Symbols and terms

Symbol	English	German
C	Capacitance	Kapazität
ΔC	Capacitance difference	Kapazitätsdifferenz
C_R	Rated capacitance	Nennkapazität
C_S	Series capacitance	Serienkapazität
$C_{S,T}$	Series capacitance at temperature T	Serienkapazität bei Temperatur T
C_f	Capacitance at frequency f	Kapazität bei Frequenz f
d	Case diameter, nominal dimension	Gehäusedurchmesser, Nennmaß
d_{max}	Maximum case diameter	Maximaler Gehäusedurchmesser
ESL	Self-inductance	Eigeninduktivität
ESR	Equivalent series resistance	Ersatzserienwiderstand
ESR_f	Equivalent series resistance at frequency f	Ersatzserienwiderstand bei Frequenz f
ESR_T	Equivalent series resistance at temperature T	Ersatzserienwiderstand bei Temperatur T
f	Frequency	Frequenz
I	Current	Strom
I_{AC}	Alternating current (ripple current)	Wechselstrom
$I_{AC,RMS}$	Root-mean-square value of alternating current	Wechselstrom, Effektivwert
$I_{AC,f}$	Ripple current at frequency f	Wechselstrom bei Frequenz f
$I_{AC,max}$	Maximum permissible ripple current	Maximal zulässiger Wechselstrom
$I_{AC,R}$	Rated ripple current	Nennwechselstrom
I_{leak}	Leakage current	Reststrom
$I_{leak,op}$	Operating leakage current	Betriebsreststrom
l	Case length, nominal dimension	Gehäuselänge, Nennmaß
l_{max}	Maximum case length (without terminals and mounting stud)	Maximale Gehäuselänge (ohne Anschlüsse und Gewindebolzen)
R	Resistance	Widerstand
R_{ins}	Insulation resistance	Isolationswiderstand
R_{symm}	Balancing resistance	Symmetrierwiderstand
T	Temperature	Temperatur
ΔT	Temperature difference	Temperaturdifferenz
T_A	Ambient temperature	Umgebungstemperatur
T_B	Capacitor base temperature	Temperatur des Gehäusebodens
T_C	Case temperature	Gehäusetemperatur
t	Time	Zeit
Δt	Period	Zeitraum
t_b	Service life (operating hours)	Brauchbarkeitsdauer (Betriebszeit)
V	Voltage	Spannung
V_F	Forming voltage	Formierspannung
V_{op}	Operating voltage	Betriebsspannung
V_R	Rated voltage, DC voltage	Nennspannung, Gleichspannung
V_S	Surge voltage	Spitzenspannung

Symbol	English	German
X_C	Capacitive reactance	Kapazitiver Blindwiderstand
X_L	Inductive reactance	Induktiver Blindwiderstand
Z	Impedance	Scheinwiderstand
Z_T	Impedance at temperature T	Scheinwiderstand bei Temperatur T
$\tan \delta$	Dissipation factor	Verlustfaktor
λ	Failure rate	Ausfallrate
ϵ_0	Absolute permittivity	Elektrische Feldkonstante
ϵ_r	Relative permittivity	Dielektrizitätszahl
ω	Angular frequency; $2 \cdot \pi \cdot f$	Kreisfrequenz; $2 \cdot \pi \cdot f$

Note:

All dimensions are given in mm.

The following applies to all products named in this publication:

- 1 Some parts of this publication contain **statements about the suitability of our products for certain areas of application**. These statements are based on our knowledge of typical requirements that are often placed on our products in the areas of application concerned. We nevertheless expressly point out **that such statements cannot be regarded as binding statements about the suitability of our products for a particular customer application**. As a rule we are either unfamiliar with individual customer applications or less familiar with them than the customers themselves. For these reasons, it is always ultimately incumbent on the customer to check and decide whether a product with the properties described in the product specification is suitable for use in a particular customer application.
- 2 We also point out that **in individual cases, a malfunction of electronic components or failure before the end of their usual service life cannot be completely ruled out in the current state of the art, even if they are operated as specified**. In customer applications requiring a very high level of operational safety and especially in customer applications in which the malfunction or failure of an electronic component could endanger human life or health (e.g. in accident prevention or life-saving systems), it must therefore be ensured by means of suitable design of the customer application or other action taken by the customer (e.g. installation of protective circuitry or redundancy) that no injury or damage is sustained by third parties in the event of malfunction or failure of an electronic component.
- 3 **The warnings, cautions and product-specific notes must be observed.**
- 4 In order to satisfy certain technical requirements, **some of the products described in this publication may contain substances subject to restrictions in certain jurisdictions (e.g. because they are classed as hazardous)**. Useful information on this will be found in our Material Data Sheets on the Internet (www.tdk-electronics.tdk.com/material). Should you have any more detailed questions, please contact our sales offices.
- 5 We constantly strive to improve our products. Consequently, **the products described in this publication may change from time to time**. The same is true of the corresponding product specifications. Please check therefore to what extent product descriptions and specifications contained in this publication are still applicable before or when you place an order.
We also **reserve the right to discontinue production and delivery of products**. Consequently, we cannot guarantee that all products named in this publication will always be available. The aforementioned does not apply in the case of individual agreements deviating from the foregoing for customer-specific products.
- 6 Unless otherwise agreed in individual contracts, **all orders are subject to our General Terms and Conditions of Supply**.
- 7 **Our manufacturing sites serving the automotive business apply the IATF 16949 standard**. The IATF certifications confirm our compliance with requirements regarding the quality management system in the automotive industry. Referring to customer requirements and customer specific requirements ("CSR") TDK always has and will continue to have the policy of respecting individual agreements. Even if IATF 16949 may appear to support the acceptance of unilateral requirements, we hereby like to emphasize that **only requirements mutually agreed upon can and will be implemented in our Quality Management System**. For clarification purposes we like to point out that obligations from IATF 16949 shall only become legally binding if individually agreed upon.

Important notes

- 8 The trade names EPCOS, CarXield, CeraCharge, CeraDiode, CeraLink, CeraPad, CeraPlas, CSMP, CTVS, DeltaCap, DigiSiMic, FilterCap, FormFit, InsuGate, LeaXield, MediPlas, MiniBlue, MiniCell, MKD, MKK, ModCap, MotorCap, PCC, PhaseCap, PhaseCube, PhaseMod, PhiCap, PiezoBrush, PlasmaBrush, PowerHap, PQSine, PQvar, SIFERRIT, SIFI, SIKOREL, SilverCap, SIMDAD, SiMic, SIMID, SineFormer, SIOV, SurfIND, ThermoFuse, WindCap, XieldCap are **trademarks registered or pending** in Europe and in other countries. Further information will be found on the Internet at www.tdk-electronics.tdk.com/trademarks.

Release 2024-02