

# MediPlas

## Reactor

**Series/Type:** V 1.0  
**Ordering code:** Z63000Z2910Z1Z84 (Prototype)  
Date: 2025-02-19  
Version: 1



**Note:** This product is a development sample and has prototype status only.  
*Cautions and warnings and Important notes* must be observed.

**Note: This product is a development sample and has prototype status only. Cautions and warnings and important notes must be observed.**

### Intended use

Electroceramic plasma reactor with dielectric barrier discharge (DBD) and integrated active cooling for the controlled generation of reactive oxygen and nitrogen species.

### Features

- Compact and highly efficient
- Active temperature control (cooling and heating)
- Easy to integrate
- Continuous operation
- Medical grade materials<sup>[1]</sup>



### Dimensional drawings in mm

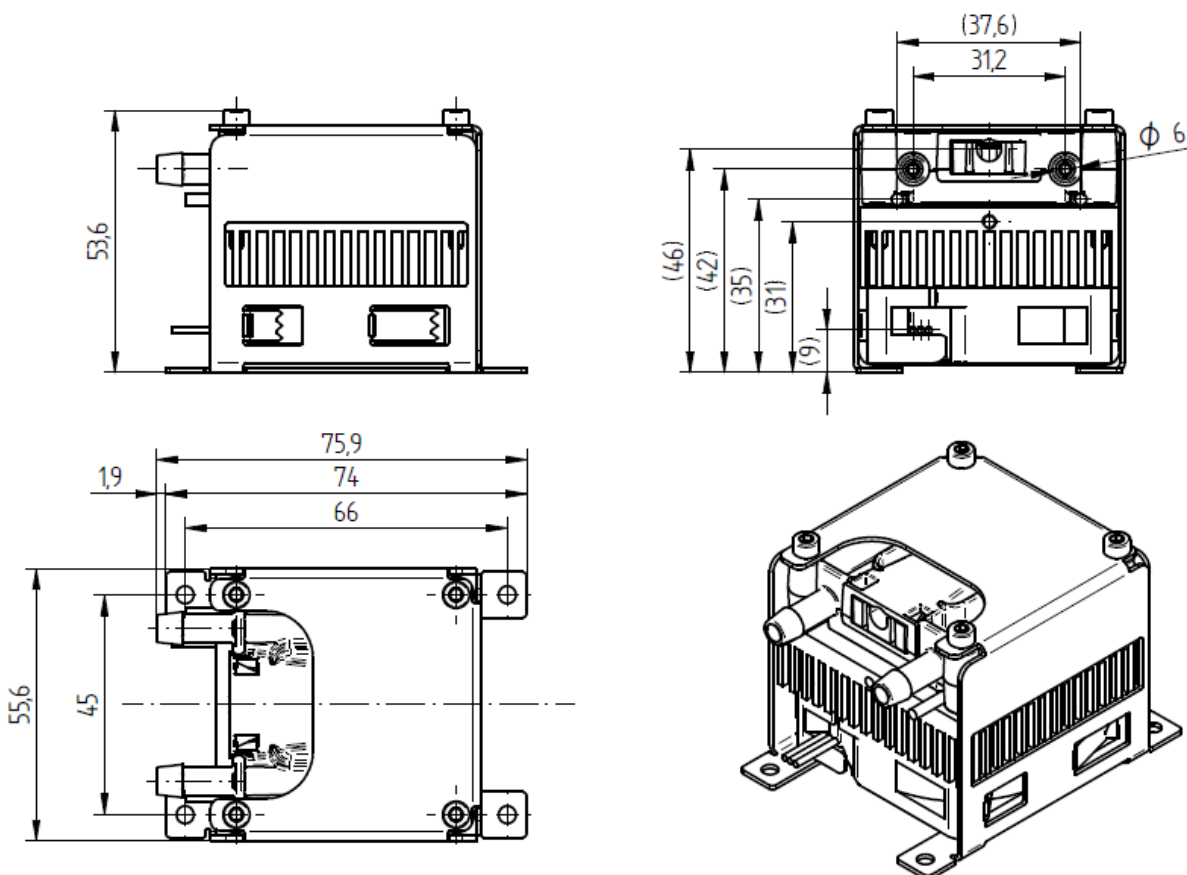

**Note: This product is a development sample and has prototype status only.  
Cautions and warnings and important notes must be observed.**

**Specification**
**■ Electrical data**

Max. continuous input power	40 W
Input voltage fan	3 ... 12 V (max. 127 mA)
Input voltage temperature control	±12 V (max. 3 A)
HV input (RMS)	1.2 ... 3.0 kV AC (< 30 kHz) (max. 30 mA peak)
Typ. ignition voltage <sup>[2]</sup>	1.2 kV (RMS) 20 kHz
Gas flow	0 ... 10 slm
Max. relative pressure <sup>[3]</sup>	200 hPa
Max. absolute pressure <sup>[4]</sup>	1200 hPa
Input gas type	Air, CDA; humid air (non condensing)
Input gas humidity <sup>[5]</sup>	0... 90% RH
Output gases <sup>[6]</sup> see "Cautions and warnings"	Air with an increased concentration of ozone (O <sub>3</sub> ); nitrogen oxide (NO <sub>x</sub> ) and hydrogen peroxide (H <sub>2</sub> O <sub>2</sub> )

<sup>[1]</sup> All materials used that come into direct or indirect contact with the inner tube system are biocompatible according to USP Class VI or ISO 10993-1. The biocompatibility of the component must be demonstrated in the final operation of the system.

<sup>[2]</sup> Condensed dry air (RH 6%), flow 0.5 slm, 20 °C environmental temperature, ambient pressure.

<sup>[3]</sup> The max. relative pressure refers only to the tightness of the system.

<sup>[4]</sup> The max. absolute pressure refers to the ignition voltage.

<sup>[5]</sup> Condense build-up in the reactor is prohibited.

<sup>[6]</sup> The output varies with operating conditions (see chapter: "Ozone production (from air)" and "Nitrogen oxides production (from air)")

**■ Dimensions and weight**

Dimensions	56 x 54 x 76 (w x h x d) mm
Weight	205 ±5 g
Operating temperature:	5 °C ... 50 °C
Agency approvals	RoHS
Cooling	Active with fan

**■ Safety specification(s)**

Standard	Designed to meet IEC 61010-1
----------	------------------------------

**■ Other specification(s)**

Standard	Mechanical shock: meets IEC 60601-1-11 chapter 10.1.2 a)
----------	--

**Note: This product is a development sample and has prototype status only.  
Cautions and warnings and important notes must be observed.**

## Interfaces

### ■ Cables and ports

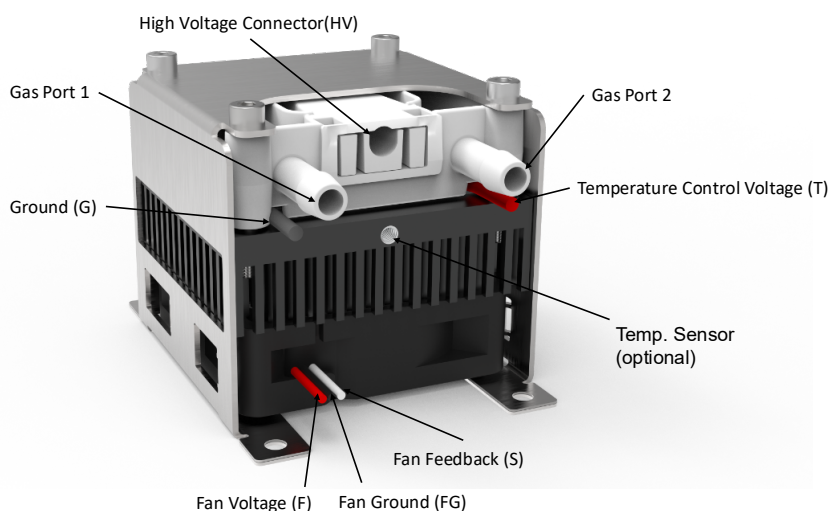

### ■ Interfaces

Interfaces	Type	Size 1	Size 2
Gas port 1	Hose connector	Ø <sub>inner</sub> 4 mm	-
Gas port 2	Hose connector	Ø <sub>inner</sub> 4 mm	-
High voltage <sup>[6]</sup>	Connector for HV cable	Ø <sub>max</sub> 5 mm	
Temperature control (T)	Wire red	AWG 20	L = 200 ±20 mm
Ground (G)	Wire black	AWG 20	L = 200 ±20 mm
Fan voltage (F) <sup>[7]</sup>	Molex 22013037 Pin 2	Wire red	L = 290 ±10 mm
Fan GND (FG) <sup>[7]</sup>	Molex 22013037 Pin 1	Wire black	L = 290 ±10 mm
Fan feedback (S) <sup>[7]</sup>	Molex 22013037 Pin 3	Wire white	L = 290 ±10 mm
Temp. sensor (optional)	Thread	M3	8 mm

<sup>[7]</sup> For installation description read "HV connection".

<sup>[6]</sup> Connect to molex 22232031 or similar.

**Note: This product is a development sample and has prototype status only.  
Cautions and warnings and important notes must be observed.**

**Work range**

Value	Min.	Typ.	Max.
Gas flow [slm]	0	1	10
Temperature control [A]	-3	2	3
Fan [V]	3	12	12
High voltage power [W]	5	10	20
O <sub>3</sub> concentration <sup>[9]</sup> [ppm]	0	2500	4000

<sup>[9]</sup> condensed dry air (RH 6%), flow 0.5 slm, 20 °C environmental temperature

**Environmental**

Range of enviroment:		indoor
Pollution degree		2
Operating temperature	°C	5 ... 50
Operating humidity	% RH	up to 85
Cooling	W	~ 40, depending on working point
Altitude (max)	m ASL	3000

**Note: This product is a development sample and has prototype status only. Cautions and warnings and important notes must be observed.**

### Temperature control

To influence the chemistry inside of the reactor, the temperature can be controlled by a thermoelectric cooler module. The ‘hot side’ is coupled to the air-cooler system.

The “reactor temperature” can be calculated by measuring the plasma power (“heat removed”) and the temperature difference of the module according to the specification of the cooler module:

Data sheet – at hot side temperature 27 °C

*Cooling capacity vs. Temperature difference (at  $T_{hot} = 27^{\circ}C$ )*

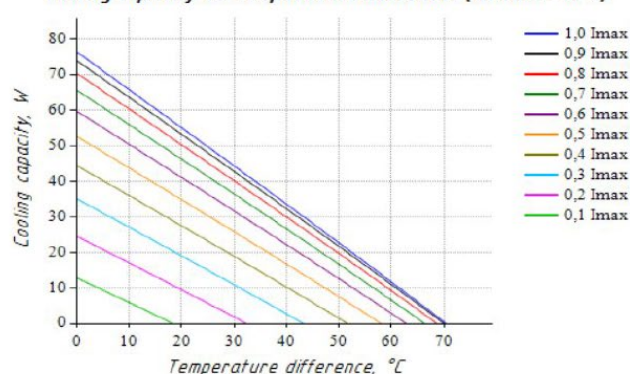

*Cooling capacity vs. Current (at  $T_{hot} = 27^{\circ}C$ )*

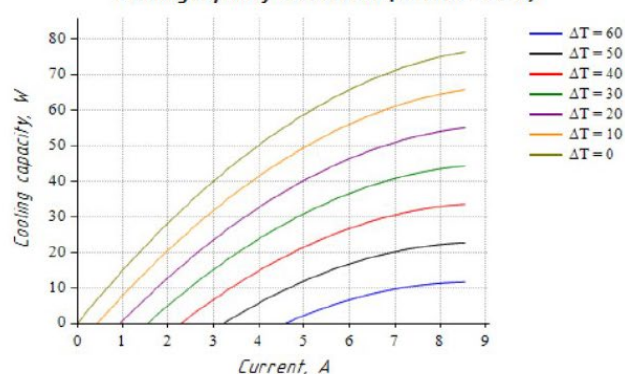

*Voltage vs. Current (at  $T_{hot} = 27^{\circ}C$ )*

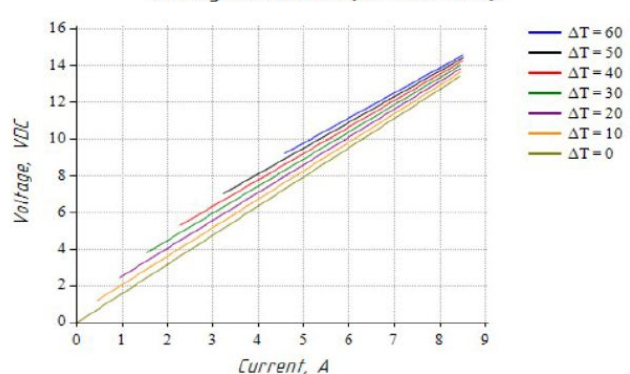

*COP vs. Current (at  $T_{hot} = 27^{\circ}C$ )*

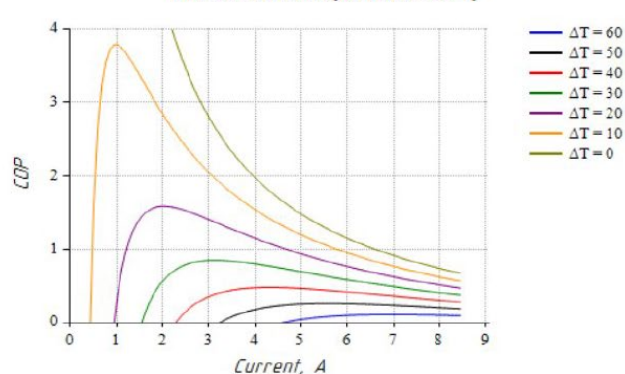

To cool the inside of the reactor, a positive voltage must be applied to the red cable opposite the black earth cable. To heat the inside, a negative voltage can also be applied.

**Note: This product is a development sample and has prototype status only.  
Cautions and warnings and important notes must be observed.**

### Pressure drop

The MediPlas Reactor is designed for a wide range of applications and operating conditions at atmospheric pressure. The gas flow  $f$  can be up to 10 slm.

The pressure drop  $dp$  across the reactor per flow  $f$  is almost linear over the entire application range and can be calculated according to:

$$dp [hPa] = 9.5 \left[ \frac{hPa}{slm} \right] \cdot f [slm] \pm 20\%$$

### Ozone production (from air)

The ozone production rate strongly depends on the electrical parameters and the composition of the feed gas. The drier the feed gas and the higher the oxygen content of the feed gas, the higher the expected ozone output of the reactor.

Depending on the set electrical parameters, the quantity and the type of feed gas used, ozone generation rates of up to 1 g/h with dry air, or up to 30 g/h with pure oxygen can be achieved on a stationary basis.

### Nitrogen oxides production (from air)

The nitrogen oxides production rate also strongly depends on the electrical parameters and the composition of the feed gas. The more DBD power and the higher the internal temperature of the reactor, the higher the expected nitrogen oxides output of the reactor.

### Installation instructions

The MediPlas Reactor is intended for installation in a device or machine. To prevent personal injury, it must be installed in such a way that the end user cannot come into direct contact with the reactor. The precautionary measures and warnings for dangers for the installer are described in the chapter "Cautions and warnings".

**Note:** The safety of a system into which the MediPlas Reactor is integrated is the sole responsibility of the installer of the system.

#### ■ Machine, device, and housing integration

The reactor has only a basic insulation, the device, machine or enclosure in which the reactor is to be integrated needs secondary measures against dangerously active voltages fulfill the typical insulation requirements.

In a device, machine or enclosure in which the reactor is to be integrated and the objective is to comply with IEC 61010-1, the mechanical, fire protection and requirements to the circuit breaker of IEC 61010-1 must be met.

The required additional circuit breaker for integration must meet the following requirements in accordance with IEC 61010-1.

- a) A switch or circuit breaker must be present in the system.
- b) The switch or circuit breaker shall be suitably located and easily accessible.
- c) The switch or circuit breaker must be labeled as a disconnecting device for the appliance.

**or**

the end product must meet the requirements for the disconnecting device of EN 61010-1.

**Note:** This product is a development sample and has prototype status only. Cautions and warnings and important notes must be observed.

■ **Mounting method**

All four mounting holes should be utilized for best mechanical performance. The recommended screw size is M3. The recommended torque for the screws is 1.5 Nm.

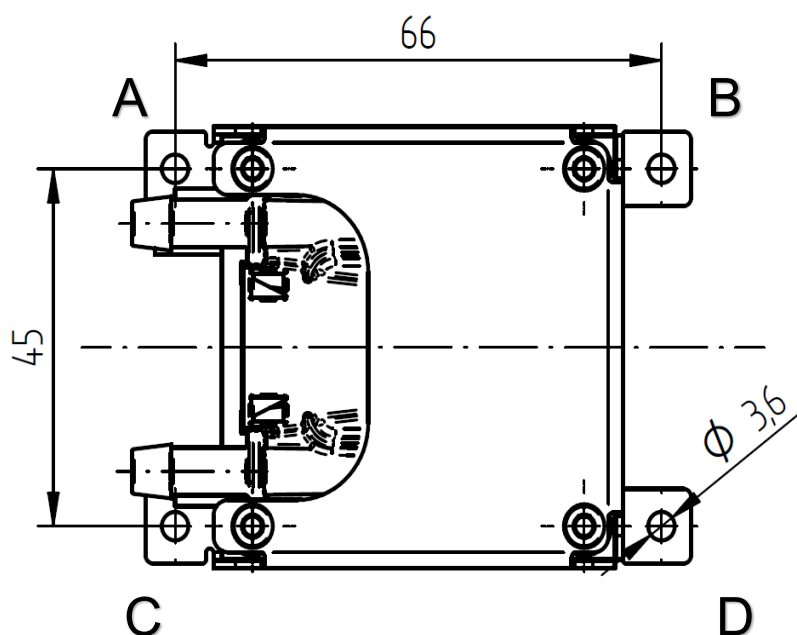

■ **Mounting directions**

Recommended standard mounting direction is (A). Mounting directions (B) to (E) are also possible.

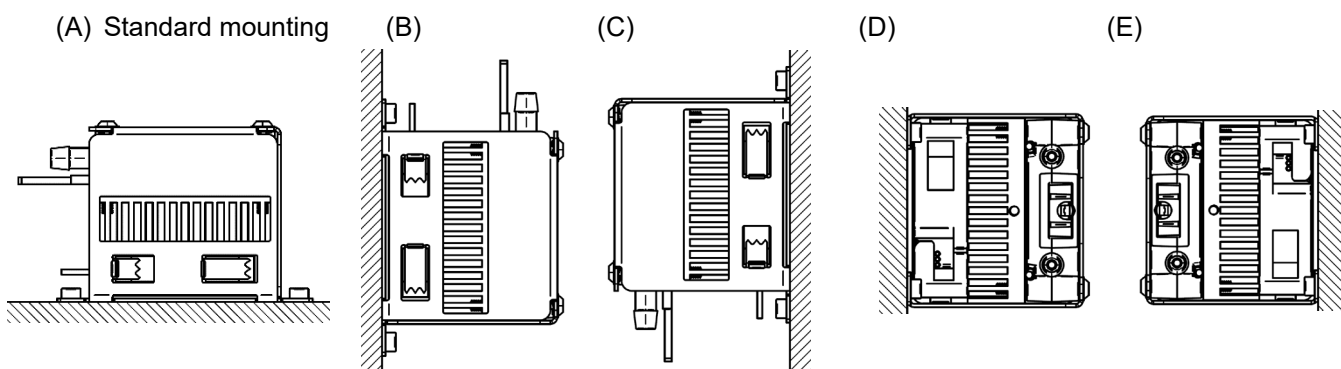

**Note: This product is a development sample and has prototype status only. Cautions and warnings and important notes must be observed.**

Installation top side down is prohibited and may cause damage to the device.

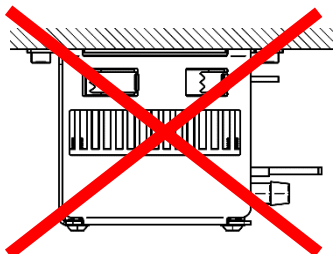

■ **Ventilation**

The device pushes with the fan air through the cooler. Make sure the air inlets and the air outlet are not blocked. **The installation with blocked inlets or outlets may cause the device to overheat and damage the device.**

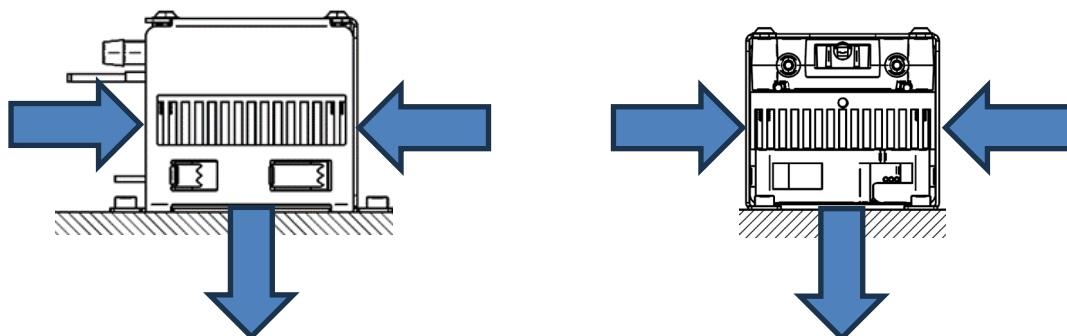

**Note: This product is a development sample and has prototype status only. Cautions and warnings and important notes must be observed.**

■ **HV connection**

Remove  $10 \pm 1$  mm from isolation of the HV cable. Press the cable in the HV connector, make sure that there is no gap between isolation and the lip of the HV connector.

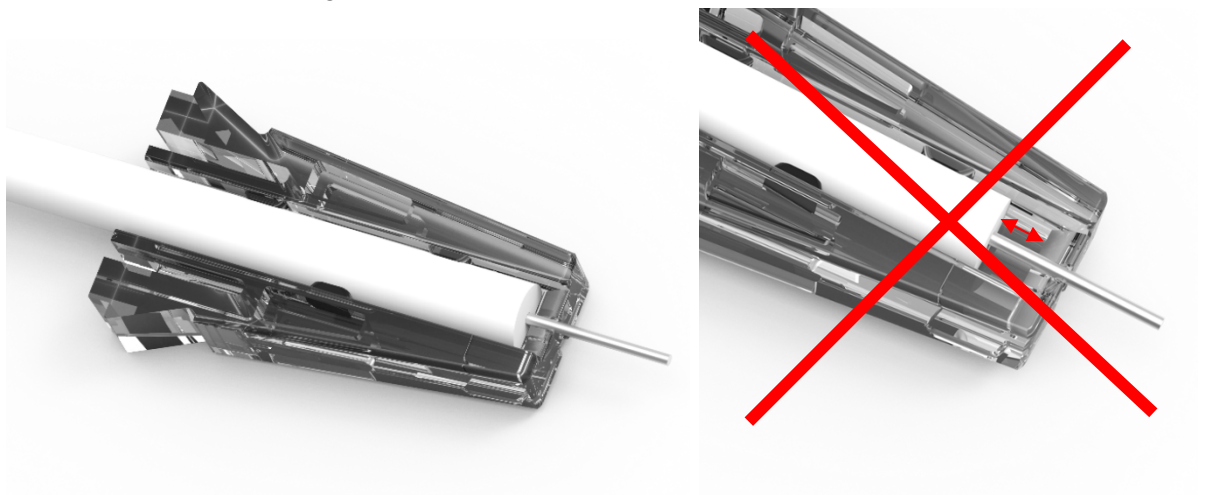

Fold the stranded wire around the HV connector.

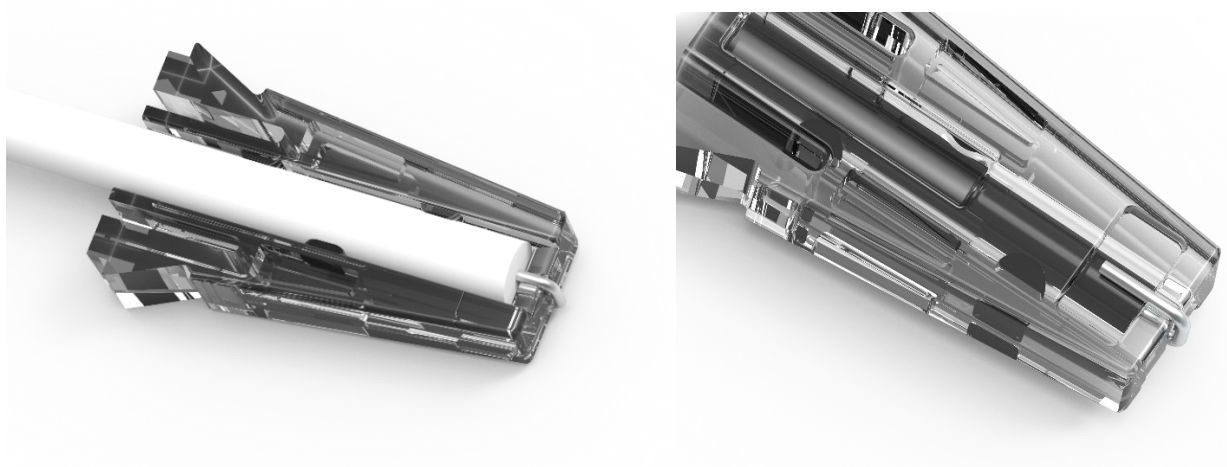

The wire should not surpass the pocket.

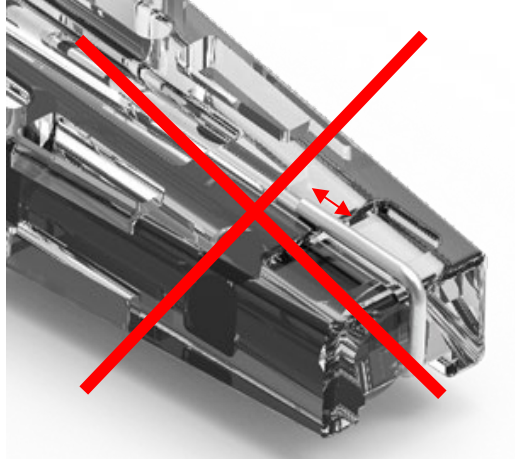

**Note: This product is a development sample and has prototype status only.  
Cautions and warnings and important notes must be observed.**

Insert the HV connector with the HV cable in the MediPlas Reactor. Make sure the connector is plugged in completely and the engagement hooks are locking the connector in the housing.

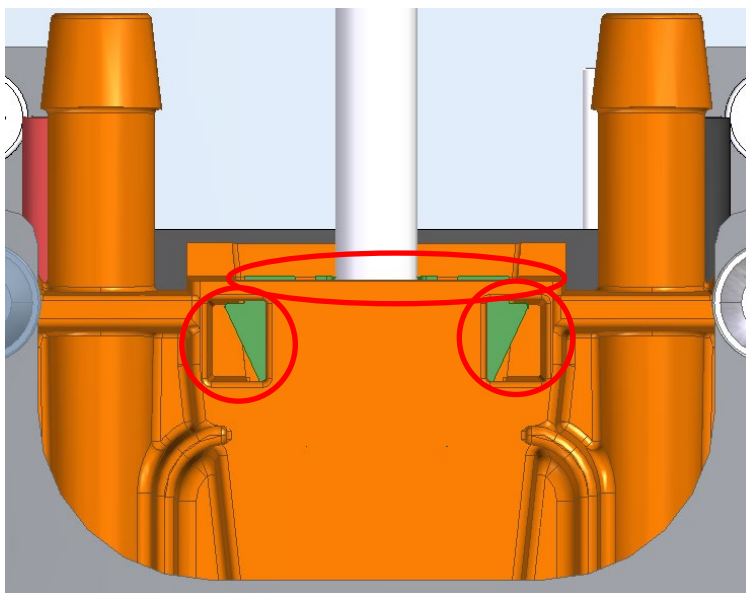

**Caution!**

High voltage! Always ensure that the high-voltage parts are connected correctly!

**Cleaning and maintenance**

No cleaning is necessary when used as intended and under the conditions described under chapter “Specification”.

There are no maintenance intervals during the lifetime of the appliance.

**Impermissible operating conditions**









The unit must not be operated under any of the following conditions:

- In environments classified as potentially explosive (EX zones)
- With insufficient ventilation or inadequate heat dissipation
- When intake air is condensing
- In areas with significant dust accumulation
- At altitudes exceeding 3000 meters above sea level
- Without active cooling provided by the integrated fan
- Without a secondary enclosure (protective casing)

The protective effect of the device may be impaired if it is used in a manner not intended by the manufacturer.



**Note: This product is a development sample and has prototype status only. Cautions and warnings and important notes must be observed.**

**Cautions and warnings**

	<p>Observe the safety instructions in this data sheet! Failure to do so can have serious consequences for the health of persons as well as damage to property and the environment. This data sheet is an integral part of the appliance and must be accessible each time it is used. Read the instructions completely before using the appliance. Only use the appliance in accordance with the instructions contained herein!</p>
	<p>Only <b>TECHNICALLY QUALIFIED SERVICE PERSONNEL</b> familiar with the principles of electrical safety shall operate this supply. <b>DO NOT EXPOSE THE POWER SUPPLY TO WATER, MOISTURE, OR DUSTY ENVIRONMENTS</b> (pollution degree 2). Electrical safety must always be maintained.</p>
	<p><b>Caution!</b> High voltage! Always ensure that the high voltage parts are connected correctly. Do not open the device. If the device is damaged, disconnect the voltage supply and contact the manufacturer.</p>
	<p><b>Caution!</b> Hot surface! The cooler surface can be hot. Do not touch during or immediately after operation.</p>
	<p>The device is designed for indoor use only. Splashing water and/or excessive humidity may cause the device to destruct or fail.</p>
	<p>Never attempt to operate the device in any manner not described in this manual. Never remove <b>DANGER</b> and <b>WARNING</b> labels from the device. Replace lost or damaged labels immediately.</p>
	<p><b>Caution!</b> Nitrogen oxides and ozone (O<sub>3</sub>)! The machine produces nitrogen oxides, ozone, and other hazardous substances, depending on feed gas supply and power settings.</p> <ul style="list-style-type: none"> <li>– Make sure the working area is well ventilated.</li> <li>– Install a sufficient gas extraction</li> <li>– Proof tightness of the gas system.</li> <li>– Note that national health and safety measures must be observed when operating the device.</li> <li>– Only use the device in well vented areas or in conjunction with a suitable extraction device.</li> <li>– Do not leave the device running unattended.</li> </ul>
	<p><b>Caution!</b></p> <ul style="list-style-type: none"> <li>– Only connect high-voltage cables with a suitable diameter to ensure a safe connection to the reactor.</li> <li>– Pay attention to the prescribed length of the insulation stripping of the high-voltage cable</li> <li>– Use appropriate fastening to prevent loosening of the device in your system.</li> <li>– After installation, check the tight fit of the HV connector and the HV stranded wire used to avoid an electrical hazard due to a loosening high-voltage cable.</li> </ul>
	<p>This product is not serviceable outside of relyon plasma GmbH. When manipulating the device, the protection provided by the product safety may be impaired.</p>

Continued on next page

**Note: This product is a development sample and has prototype status only.  
Cautions and warnings and important notes must be observed.**

	<p>Before adjusting or changing the device, make sure that the device is in a safe state by switching off the associated high-voltage generator or disconnecting it from all associated power or voltage supply lines.</p>
	<p>If the product is used in a manner not specified in this data sheet the protection provided by the product safety may be impaired.</p>

This listing does not claim to be complete but merely reflects the experience of TDK.

### Display of ordering codes for TDK Electronics products

The ordering code for one and the same product can be represented differently in data sheets, data books, other publications, on the company website, or in order-related documents such as shipping notes, order confirmations and product labels. **The varying representations of the ordering codes are due to different processes employed and do not affect the specifications of the respective products.** Detailed information can be found on the Internet under <http://www.tdk-electronics.tdk.com/orderingcodes>.

## Important notes

The following applies to all products named in this publication:

1. Some parts of this publication contain **statements about the suitability of our products for certain areas of application**. These statements are based on our knowledge of typical requirements that are often placed on our products in the areas of application concerned. We nevertheless expressly point out **that such statements cannot be regarded as binding statements about the suitability of our products for a particular customer application**. As a rule we are either unfamiliar with individual customer applications or less familiar with them than the customers themselves. For these reasons, it is always ultimately incumbent on the customer to check and decide whether a product with the properties described in the product specification is suitable for use in a particular customer application.
2. We also point out that **in individual cases, a malfunction of electronic components or failure before the end of their usual service life cannot be completely ruled out in the current state of the art, even if they are operated as specified**. In customer applications requiring a very high level of operational safety and especially in customer applications in which the malfunction or failure of an electronic component could endanger human life or health (e.g. in accident prevention or life-saving systems), it must therefore be ensured by means of suitable design of the customer application or other action taken by the customer (e.g. installation of protective circuitry or redundancy) that no injury or damage is sustained by third parties in the event of malfunction or failure of an electronic component.
3. **The warnings, cautions and product-specific notes must be observed.**
4. In order to satisfy certain technical requirements, **some of the products described in this publication may contain substances subject to restrictions in certain jurisdictions (e.g. because they are classed as hazardous)**. Useful information on this will be found in our Material Data Sheets on the Internet ([www.tdk-electronics.tdk.com/material](http://www.tdk-electronics.tdk.com/material)). Should you have any more detailed questions, please contact our sales offices.
5. We constantly strive to improve our products. Consequently, **the products described in this publication may change from time to time**. The same is true of the corresponding product specifications. Please check therefore to what extent product descriptions and specifications contained in this publication are still applicable before or when you place an order.

We also **reserve the right to discontinue production and delivery of products**. Consequently, we cannot guarantee that all products named in this publication will always be available. The aforementioned does not apply in the case of individual agreements deviating from the foregoing for customer-specific products.

6. Unless otherwise agreed in individual contracts, **all orders are subject to our General Terms and Conditions of Supply**.
7. **Our manufacturing sites serving the automotive business apply the IATF 16949 standard**. The IATF certifications confirm our compliance with requirements regarding the quality management system in the automotive industry. Referring to customer requirements and customer specific requirements ("CSR") TDK always has and will continue to have the policy of respecting individual agreements. Even if IATF 16949 may appear to support the acceptance of unilateral requirements, we hereby like to emphasize that **only requirements mutually agreed upon can and will be implemented in our Quality Management System**. For clarification purposes we like to point out that obligations from IATF 16949 shall only become legally binding if individually agreed upon.

## Important notes

8. The trade names EPCOS, CarXield, CeraCharge, CeraDiode, CeraLink, CeraPad, CeraPlas, CSMP, CTVS, DeltaCap, DigiSiMic, FilterCap, FormFit, InsuGate, LeaXield, MediPlas, MiniBlue, MiniCell, MKD, MKK, ModCap, MotorCap, PCC, PhaseCap, PhaseCube, PhaseMod, PhiCap, PiezoBrush, PlasmaBrush, PowerHap, PQSine, PQvar, SIFERRIT, SIFI, SIKOREL, SilverCap, SIMDAD, SiMic, SIMID, SineFormer, SIOV, SurfIND, ThermoFuse, WindCap, XieldCap are **trademarks registered or pending** in Europe and in other countries. Further information will be found on the Internet at [www.tdk-electronics.tdk.com/trademarks](http://www.tdk-electronics.tdk.com/trademarks).

Release 2024-02

**Manufacturer**

**relyon plasma GmbH**  
A TDK Group Company

Osterhofener Straße 6  
93055 Regensburg  
Germany

Phone: +49-941-60098-0

Fax: +49-941-60098-100

Email: [info-relyon@tdk.com](mailto:info-relyon@tdk.com)

<https://www.relyon-plasma.com>

