

# MediPlas

## Driver

**Series/Type:** V 7.0  
**Ordering code:** Z63000Z2910Z1Z83 (Prototype)  
**Date:** 2025-02-19  
**Version:** 3



**Note:** This product is a development sample and has prototype status only.  
*Cautions and warnings and Important notes must be observed.*

**Note: This product is a development sample and has prototype status only. Cautions and warnings and important notes must be observed.**

### Intended use

HV driver for DBD loads

### Features

- Compact
- Passive cooling
- Broad capacitance range of applicable loads
- Adjustable output voltage
- PWM power control input
- Process monitoring signal
- Overheating protection with auto recovery



### Dimensional drawings in mm

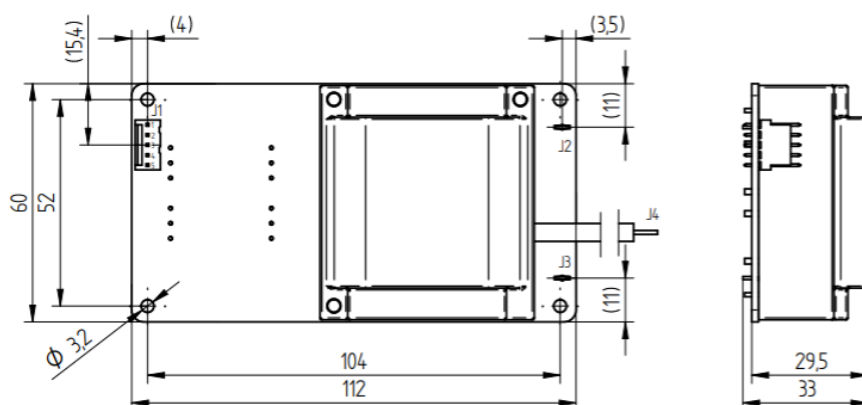

Figure 1

**Note: This product is a development sample and has prototype status only.  
Cautions and warnings and important notes must be observed.**

## Specification

### ■ Electrical data

Output voltage range $U_{HV}$ (proportional to input voltage)	1.2 ... 2.7 kV AC RMS 4.5 kV AC PEAK <sub>MAX</sub>
Output frequency range	20 ... 30 kHz (auto resonant)
Input voltage range $U_{DC}$	12.0 ... 24.0 V DC
Maximal continuous input power	30 W
HV-output connection	HV cable
Input/output connection	Connector (see pin configuration)
Device protection functions	Reverse polarity Input overvoltage Input undervoltage Overtemperature
Control input: Enable	HV output control via PWM up to 100 Hz or DC ON/OFF
Diagnostic output	PLASMA_OK (attenuated analogue feedback signal)
Steady state settling time	< 2 ms (load dependent)
Inrush current (typical, cold start)	35 A peak @ 24 V DC
Load capacitance range	5 ... 80 pF, see Figure 2
Load resistance range	0.3 ... 1 M $\Omega$ , see Figure 2
Minimum load	5 pF, 1 M $\Omega$
Stored energy	< 1.5 mJ
Overvoltage category According to IEC 61010-1	Class II

### ■ Dimensions and weight

Length	112 mm (board only; see Figure 1)
Width	60 mm
Height	33 mm
Mounting hole diameter	3.2 mm
Mounting hole spacing, length	104 mm
Mounting hole spacing, width	52 mm
HV connector (J4)	Silicone cable $\varnothing$ 4.57 mm; 22 AWG; length 160 mm, Striped end l = 10.5 mm
Weight	260 g

**Note: This product is a development sample and has prototype status only.  
Cautions and warnings and important notes must be observed.**

■ **Environmental conditions**

Operating temperature range	5 ... 50 °C
Operating altitude	≤ 3000 m
Humidity	< 80%, non-condensing
Pollution rating according to IEC 61010-1	Degree 2
Usage	Indoor only

■ **Safety specification(s)**

Standard	Designed to meet IEC 61010-1
----------	------------------------------

■ **Other specification(s)**

Standard	Mechanical shock: meets IEC 60601-1-11 chapter 10.1.2 a)
----------	--

**Description**

The MediPlas driver is a DC-AC high-voltage driver for operation with igniting DBD (Dielectric Barrier Discharge) or non-igniting high-voltage loads. The DC voltage on the input side is converted into a high-frequency high voltage by means of an auto-resonant circuit.

The operating frequency of this output voltage depends on the load, and the level of the high voltage depends on the input DC current level. To switch on the driver, the ENABLE input must be activated. In addition, a PWM signal can be used at the ENABLE input to achieve power regulation at the output.

When operating an igniting DBD load, the PLASMA\_OK feedback signal can be used to infer the intensity of the plasma discharges. The level of this signal depends on the process and environmental conditions of the DBD load.

**Note: This product is a development sample and has prototype status only. Cautions and warnings and important notes must be observed.**

### Pin configuration and functions

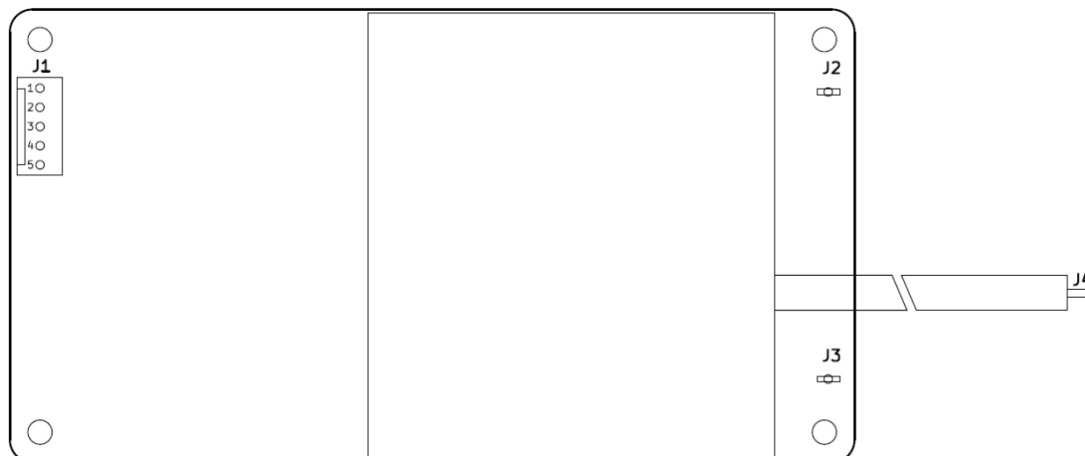

Ref.	Pin	Name	Comment
J1	1	U_DC	Supply voltage
	2	GND	Ground potential
	3	GND_SIG	Optional GND reference for PLASMA_OK and/or ENABLE signal
	4	PLASMA_OK	Signal voltage
	5	ENABLE	PWM or DC control
J2	-	GND	Ground potential
J3*	-	GND	Ground potential
J4	-	U_HV	High voltage (AC) output

\* J3 GND\_HV is functional identical to J2 connection. When used with MediPlas reactor, this connection facilitates wiring.

Table 1: Pin-out signal names

#### ■ U\_DC

U\_DC is the voltage supply pin of the driver. The logic supply and the power supply are provided via this input. The AC output voltage can be set via the level of the U\_DC voltage. Figure 3: “AC high voltage output RMS over DC input voltage” shows the U\_HV (RMS) over U\_DC in the steady state for minimum and maximum load.

#### ■ ENABLE

The ENABLE input is required to control U\_HV output. For continuous ON mode, a voltage higher than the EN<sub>TH</sub> threshold must be applied to the ENABLE input. The switch-on and switch-off phases of the U\_HV can be controlled by using a pulse-width modulated signal. The U\_HV output is enabled in the high phases of the PWM and disabled in the low phases of the PWM. The ENABLE signal has an internal signal delay EN<sub>DEL</sub> that limits the minimum duty cycle of the PWM signal. This is dependent on the PWM frequency. Table 2: “Electrical characteristics of the ENABLE input” shows the electrical characteristics and the formula for calculating the minimum required duty cycle.

**Note: This product is a development sample and has prototype status only. Cautions and warnings and important notes must be observed.**

Parameter		Min.	Typ.	Max.	Unit
EN	Enable voltage	0	-	65	V
EN <sub>TH</sub>	Enable threshold	2.0	-	-	V
EN <sub>THH</sub>	Enable threshold hysteresis	-	0.2	-	V
EN <sub>PWM</sub>	PWM frequency	-	-	100	Hz
EN <sub>D</sub>	Duty cycle	$1.06 \times 10^{-3} s \times EN_{PWM}$	-	1	s/s
EN <sub>DEL</sub>	Enable delay time	0.58	0.75	1.06	ms

Table 2: Electrical characteristics of the ENABLE input

### ■ PLASMA\_OK

The PLASMA\_OK output is a feedback signal for process monitoring of the intensity of the plasma discharge. The signal is only provided during active DBD plasma discharge cycles. The signal is load- and process-dependent. If U\_DC and ENABLE are in HIGH state, the PLASMA\_OK signal shows an analogue signal which is proportional to the U\_HV output discharge power.

For stable signal acquisition a terminating resistor of > 100 kΩ is recommended.

### Device protection functions

The MediPlas driver has 3 different protective functions. These device protective functions are protecting the driver from damage if it is operated outside the specified operating and ambient conditions. If the maximum supply voltage or the temperature threshold is exceeded or if the supply voltage falls below the minimum supply voltage, the driver is switched off. When the normal operating or ambient conditions are reached again, the driver automatically goes back into operation. Table 3: “Trigger thresholds and hysteresis of the protection functions” shows the threshold values for the device protection functions and the associated hysteresis when exceeded.

Parameter		Min.	Typ.	Max.	Unit	Reset
U_DC <sub>OVPT</sub>	Over voltage protection threshold	28.3	30.0	32.0	V	Auto recovery
U_DC <sub>OVPH</sub>	Over voltage protection hysteresis	-	-	3.6	V	
U_DC <sub>UVLOT</sub>	Under voltage lockout threshold	8.4	10.7	11.8	V	Auto recovery
U_DC <sub>UVLOH</sub>	Under voltage protection hysteresis	-	-	1.2	V	
T <sub>OVT</sub>	Over temperature protection	88	90	93	°C	Auto recovery
T <sub>OVTH</sub>	Over temperature protection hysteresis	-	10	-	°C	

Table 3: Trigger thresholds and hysteresis of the protection functions

**Note: This product is a development sample and has prototype status only. Cautions and warnings and important notes must be observed.**

### Input power and high voltage output

#### ■ Input

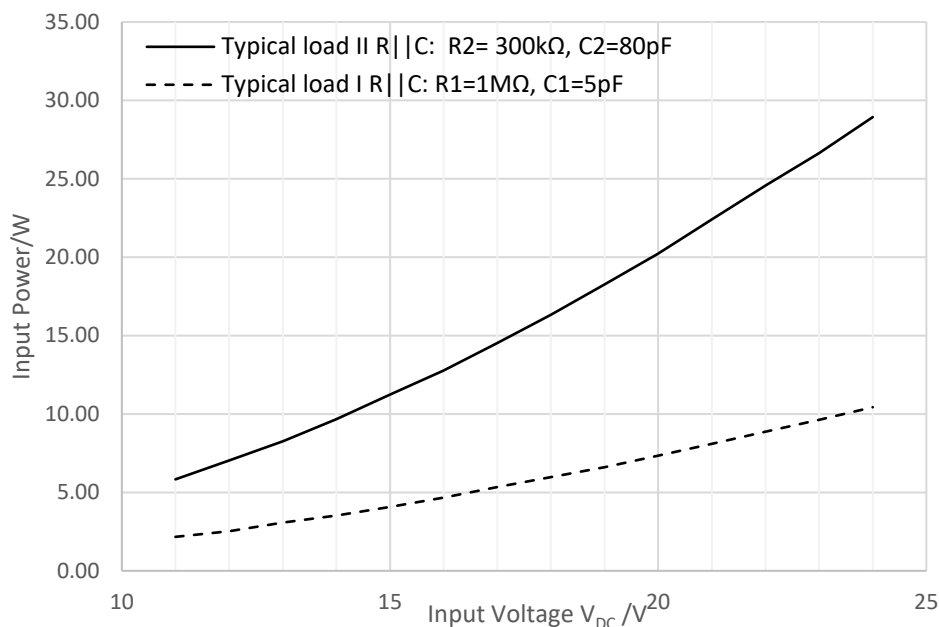

Figure 2: DC Input power over DC input voltage for typical loads

#### ■ Output

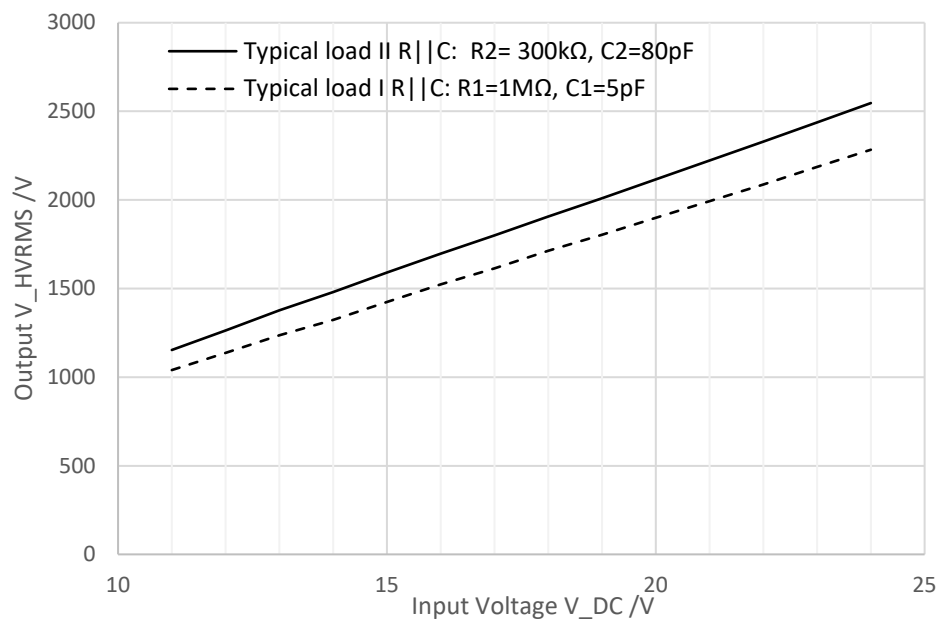

Figure 3: AC high voltage output RMS over DC input voltage

**Note: This product is a development sample and has prototype status only. Cautions and warnings and important notes must be observed.**

### Installation instructions

The MediPlas driver is intended for installation in a device or machine. To prevent personal injury, the driver must be installed in such a way that the end user cannot come into direct contact with the driver. The precautionary measures and warnings for dangers for the installer are described in the chapter "Cautions and warnings".

Note: The safety of a system into which the MediPlas driver is integrated is the sole responsibility of the installer of the system!

#### ■ Machine, device, and housing integration

In a device, machine or enclosure in which the driver is to be integrated and the objective is to comply with IEC 61010-1, the mechanical, fire protection and requirements to the circuit breaker of IEC 61010-1 must be met.

A required additional energy-limiting circuit in the end device must limit the current consumption of the driver in the event of a fault. The supply current must be limited to a maximum of 6.25 A by fuses, circuit breakers, thermal releases, current-limiting impedances or similar devices.

The required additional circuit breaker for integration must meet the following requirements in accordance with IEC 61010-1:

- a) A switch or circuit breaker must be present in the system.
- b) The switch or circuit breaker shall be suitably located and easily accessible.
- c) The switch or circuit breaker must be labeled as a disconnecting device for the appliance.

**or**

The end product must meet the requirements for the disconnecting device of EN 61010-1.

#### ■ Mounting method

Insert the spacer (metal or insulator) of height more than 8 mm to all mounting holes to lift the unit. All four mounting holes should be utilized for best mechanical performance. The recommended screw size is M3. The head diameter of the screw used must not exceed 6.0 mm. The recommended torque for the screws is 0.5 Nm. The four mounting holes are electrically isolated and provide mechanical mounting only.

**Note:** This product is a development sample and has prototype status only. Cautions and warnings and important notes must be observed.

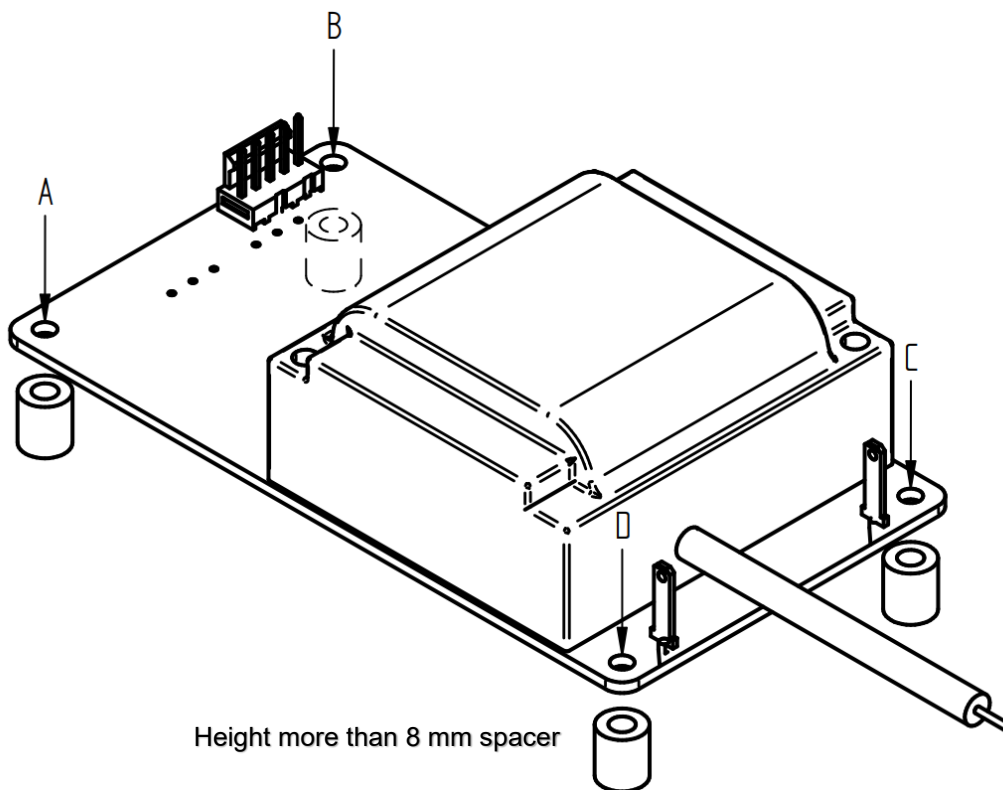

■ **Mounting directions**

Recommended standard mounting direction is (A). Mounting direction (B)-(E) are also possible.

(A) Standard mounting

(B)

(C)

(D)

(E)

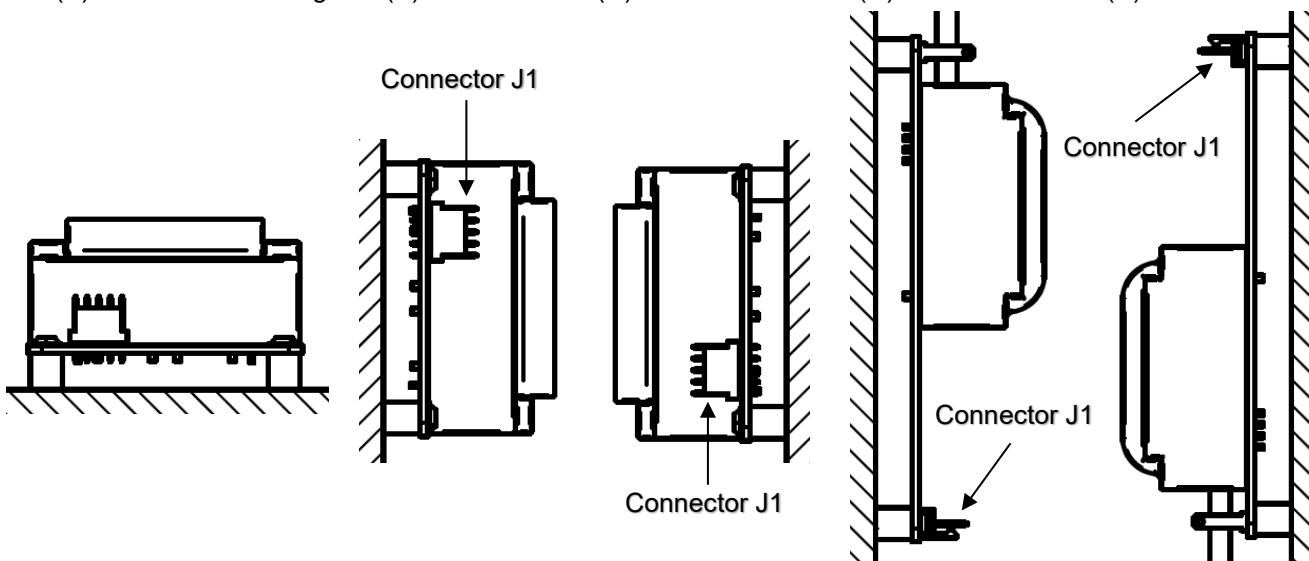

**Note: This product is a development sample and has prototype status only.  
Cautions and warnings and important notes must be observed.**

■ **Input/output connectors**

Ref.	Connector	Maker	Mating connector(s)	Maker	Comment
J1	0022232051	molex	0022013057 or similar	molex	Recommended wire size is AWG 22
J2	63756-1	TE Connectivity	Quick disconnect receptacle 2.8 mm x 0.81 mm	-	Recommended wire size is ≥ AWG 22
J3					
J4	-	-	-	-	Silicone cable Ø 4.57 mm; 22 AWG; length 160 mm, striped end l= 10.5 mm

■ **Power supply**











The driver must be supplied by a DC power supply unit with an output of ≥ 30 watts which fulfills IEC 61010-1 or certified after IEC/EN 60601-1.

■ **Cleaning**

No cleaning is necessary when used as intended and under the conditions described under chapter "Specification".



**Note: This product is a development sample and has prototype status only. Cautions and warnings and important notes must be observed.**

**Cautions and warnings**

	<p>Observe the safety instructions in this data sheet! Failure to do so can have serious consequences for the health of persons as well as damage to property and the environment. This data sheet is an integral part of the appliance and must be accessible each time it is used. Read the instructions completely before using the appliance. Only use the appliance in accordance with the instructions contained herein!</p>
	<p>Only <b>TECHNICALLY QUALIFIED SERVICE PERSONNEL</b> familiar with the principles of electrical safety shall operate this supply. <b>DO NOT EXPOSE THE POWER SUPPLY TO WATER, MOISTURE, OR DUSTY ENVIRONMENTS</b> (pollution degree 2). Electrical safety must always be maintained.</p>
	<p><b>Caution!</b> High voltage! Always ensure that the high voltage parts are connected correctly. Do not open the device. If the device is damaged, disconnect the voltage supply and contact the manufacturer.</p>
	<p><b>Caution!</b> High voltage! Do not touch the device and connecting cables during operation. All parts of the device can carry high voltages during operation. After disconnecting the supply voltage, wait at least one minute and make sure by measurement that the input capacitors are discharged before touching the device.</p>
	<p>The device has integrated device protection functions which switch off the high voltage at the output when triggered. When the device returns to the specified ambient and operating conditions, the high voltage at the output is automatically released again.</p>
	<p><b>Caution!</b> Do not use the device in a flammable or explosive atmosphere.</p>
	<p><b>Caution!</b> Do not operate the device if it is damaged.</p>
	<p>The device is designed for indoor use only. Splashing water and/or excessive humidity may cause the device to destruct or fail.</p>
	<p>Never attempt to operate the power supply in any manner not described in this manual. Never remove <b>DANGER</b> and <b>WARNING</b> labels from the device. Replace lost or damaged labels immediately.</p>
	<p>Do not use screws with a head diameter &gt; 6.0 mm to mount the driver.</p>
	<p>If the product is used in a manner not specified in this data sheet the protection provided by the product safety may be impaired.</p>

Continued on next page

**Note: This product is a development sample and has prototype status only. Cautions and warnings and important notes must be observed.**

	This product is not serviceable outside of relyon plasma GmbH. When manipulating the device, the protection provided by the product safety may be impaired.
	Before adjusting or changing the device, make sure that the device is in a safe state by switching off the associated high-voltage generator or disconnecting it from all associated power or voltage supply lines.
	When operating this device with plasma reactors (intended use), high EMI with other devices can/will occur. When used with a plasma reactor, it is recommended to keep the connecting cables short and shield both devices accordingly.

This listing does not claim to be complete but merely reflects the experience of TDK.

### Display of ordering codes for TDK Electronics products

The ordering code for one and the same product can be represented differently in data sheets, data books, other publications, on the company website, or in order-related documents such as shipping notes, order confirmations and product labels. **The varying representations of the ordering codes are due to different processes employed and do not affect the specifications of the respective products.** Detailed information can be found on the Internet under <http://www.tdk-electronics.tdk.com/orderingcodes>.

## Important notes

The following applies to all products named in this publication:

1. Some parts of this publication contain **statements about the suitability of our products for certain areas of application**. These statements are based on our knowledge of typical requirements that are often placed on our products in the areas of application concerned. We nevertheless expressly point out **that such statements cannot be regarded as binding statements about the suitability of our products for a particular customer application**. As a rule we are either unfamiliar with individual customer applications or less familiar with them than the customers themselves. For these reasons, it is always ultimately incumbent on the customer to check and decide whether a product with the properties described in the product specification is suitable for use in a particular customer application.
2. We also point out that **in individual cases, a malfunction of electronic components or failure before the end of their usual service life cannot be completely ruled out in the current state of the art, even if they are operated as specified**. In customer applications requiring a very high level of operational safety and especially in customer applications in which the malfunction or failure of an electronic component could endanger human life or health (e.g. in accident prevention or life-saving systems), it must therefore be ensured by means of suitable design of the customer application or other action taken by the customer (e.g. installation of protective circuitry or redundancy) that no injury or damage is sustained by third parties in the event of malfunction or failure of an electronic component.
3. **The warnings, cautions and product-specific notes must be observed.**
4. In order to satisfy certain technical requirements, **some of the products described in this publication may contain substances subject to restrictions in certain jurisdictions (e.g. because they are classed as hazardous)**. Useful information on this will be found in our Material Data Sheets on the Internet ([www.tdk-electronics.tdk.com/material](http://www.tdk-electronics.tdk.com/material)). Should you have any more detailed questions, please contact our sales offices.
5. We constantly strive to improve our products. Consequently, **the products described in this publication may change from time to time**. The same is true of the corresponding product specifications. Please check therefore to what extent product descriptions and specifications contained in this publication are still applicable before or when you place an order.

We also **reserve the right to discontinue production and delivery of products**. Consequently, we cannot guarantee that all products named in this publication will always be available. The aforementioned does not apply in the case of individual agreements deviating from the foregoing for customer-specific products.

6. Unless otherwise agreed in individual contracts, **all orders are subject to our General Terms and Conditions of Supply**.
7. **Our manufacturing sites serving the automotive business apply the IATF 16949 standard**. The IATF certifications confirm our compliance with requirements regarding the quality management system in the automotive industry. Referring to customer requirements and customer specific requirements ("CSR") TDK always has and will continue to have the policy of respecting individual agreements. Even if IATF 16949 may appear to support the acceptance of unilateral requirements, we hereby like to emphasize that **only requirements mutually agreed upon can and will be implemented in our Quality Management System**. For clarification purposes we like to point out that obligations from IATF 16949 shall only become legally binding if individually agreed upon.

## Important notes

8. The trade names EPCOS, CarXield, CeraCharge, CeraDiode, CeraLink, CeraPad, CeraPlas, CSMP, CTVS, DeltaCap, DigiSiMic, FilterCap, FormFit, InsuGate, LeaXield, MediPlas, MiniBlue, MiniCell, MKD, MKK, ModCap, MotorCap, PCC, PhaseCap, PhaseCube, PhaseMod, PhiCap, PiezoBrush, PlasmaBrush, PowerHap, PQSine, PQvar, SIFERRIT, SIFI, SIKOREL, SilverCap, SIMDAD, SiMic, SIMID, SineFormer, SIOV, SurfIND, ThermoFuse, WindCap, XieldCap are **trademarks registered or pending** in Europe and in other countries. Further information will be found on the Internet at [www.tdk-electronics.tdk.com/trademarks](http://www.tdk-electronics.tdk.com/trademarks).

Release 2024-02

## **Manufacturer**

**relyon plasma GmbH**  
**A TDK Group Company**

Osterhofener Straße 6  
93055 Regensburg  
Germany

Phone: +49-941-60098-0

Fax: +49-941-60098-100

Email: [info-relyon@tdk.com](mailto:info-relyon@tdk.com)

<https://www.relyon-plasma.com>

