

## **1 EMC basics**

### **1.1 Legal background**

Electromagnetic compatibility (EMC) has become an essential property of electronic equipment. In view of the importance of this topic, the European legislator issued the EMC Directive as early as 1996 (89/336/EEC): it has since been incorporated at national level by the EU member states in the form of various EMC laws and regulations. The current version of the EMC directive (2004/108/EC of December 15<sup>th</sup>, 2004) is now binding on all equipment put on the market.

The EMC directive understands the term "equipment" as referring to both movable apparatus and fixed installations. Although CE marking is not mandatory for the latter, these must, just like the equipment for which such marking is mandatory, observe the basic protection requirements.

However, movable apparatus covers all equipment ready for use by the end user, as well as electronic subassemblies with an autonomous function which are manufactured in series and are not designed exclusively for assembly in a specific fixed installation. However, basic components such as capacitors, inductors and EMC filters are excluded from the EMC directive and must not be CE-marked.

### **1.2 Directives and CE marking**

Manufacturers must declare that their apparatus conforms to the protection objectives of the EMC Directive by attaching a declaration of conformity as well as a CE conformity mark to all equipment and packaging. This implies that they assume responsibility vis-à-vis the legislators for observing the relevant emission limits and interference immunity requirements. The harmonized standards listed under the Directive in the Official Journal of the EU are a recognized basis for the declaration of conformity. On this point, see also Section 1.8.

The interference immunity requirements in particular are becoming increasingly important for the operators of equipment, installations and systems, as their correct functioning can be ensured only if sufficient EMC measures are taken. However, the need for constant functionality also implies high availability of installations and systems and thus represents a significant performance figure for the cost-effective operation of the equipment.

It should be noted that the CE conformity mark certifies not only electromagnetic compatibility but also the observance of all EU Directives relevant to the product in question. The most important general directives are, in addition to the EMC Directive, the Low Voltage and Machine Directives.

Some of these directives also include EMC requirements. Examples are the R&TTE Directive (radio and telecommunications terminal equipment) and the Medical Products Directive. The EMC Directive does not apply to products lying within the scope of these directives.

The manufacturer is responsible for taking steps to observe all the applicable directives.

### 1.3 Fundamentals of EMC

The term EMC covers electromagnetic emissions and electromagnetic susceptibility (Figure 1).

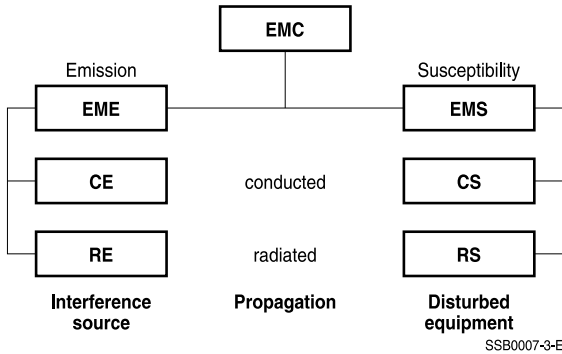

Figure 1 EMC terms

- EMC = Electromagnetic compatibility
- EME = Electromagnetic emission
- EMS = Electromagnetic susceptibility
- CE = Conducted emission
- CS = Conducted susceptibility
- RE = Radiated emission
- RS = Radiated susceptibility

The electromagnetic energies emitted by an interference source may be conducted or radiated. This also applies to the electromagnetic susceptibility of an interference sink.

To ensure cost-effective solutions, it is necessary to observe not only a subsector of EMC (such as conducted emissions), but also both types of propagation (conducted and radiated) as well as the interference immunity of an item of equipment.

## General technical information

EMC components such as filters and chokes are used to limit conducted electromagnetic interference to a level specified in EMC plans, or to reduce it below the limits set in the standards. These components may be assigned either to the interference source or the interference sink (Figure 2).

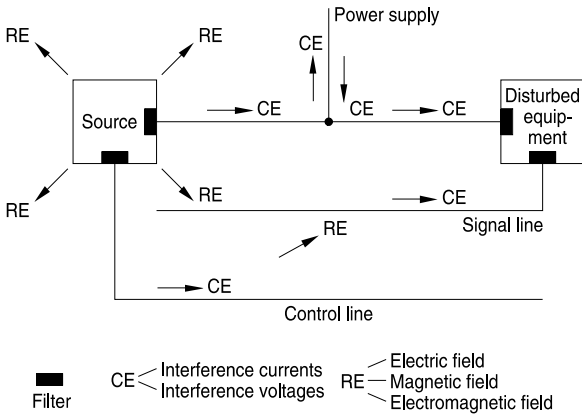

SSB1685-G-E

Figure 2 Influence model and filtering

EPCOS offers EMC components for both power lines and for signal and control lines in a wide range of voltages and currents.

### 1.4 Interference sources and sinks

An **interference source** is an electric equipment that emits electromagnetic interference. Two main groups can be distinguished depending on the type of emitted frequency range (Figure 3).

Interference sources with discrete frequency spectra, such as RF generators and microprocessor systems, emit their interference energy in concentrated form on narrow frequency bands.

Switchgear and electric motors in domestic appliances distribute their interfering energy along wide frequency bands and are assigned to interference sources with a continuous frequency spectrum. This also includes the interference spectrum generated by the switching edges of power electronics equipment. In addition, mixed forms such as fluctuating clock frequencies are increasingly encountered.

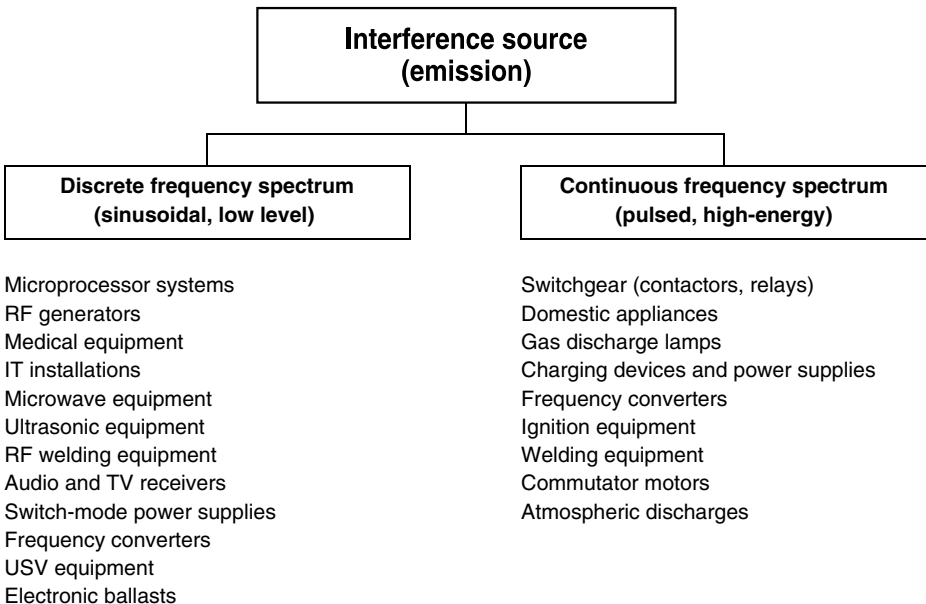

Figure 3 Interference sources

**General technical information**

Electrical equipment or installations which are exposed to interference and can be perturbed by it are known as **disturbed equipment**.

In the same way as interference sources, disturbed equipment can also be classified in terms of their frequency characteristic. A distinction is made between narrowband and broadband interference (Figure 4).

Narrowband systems are selectively operating equipment such as radio and TV sets, whereas IT equipment is usually assigned to broadband systems.

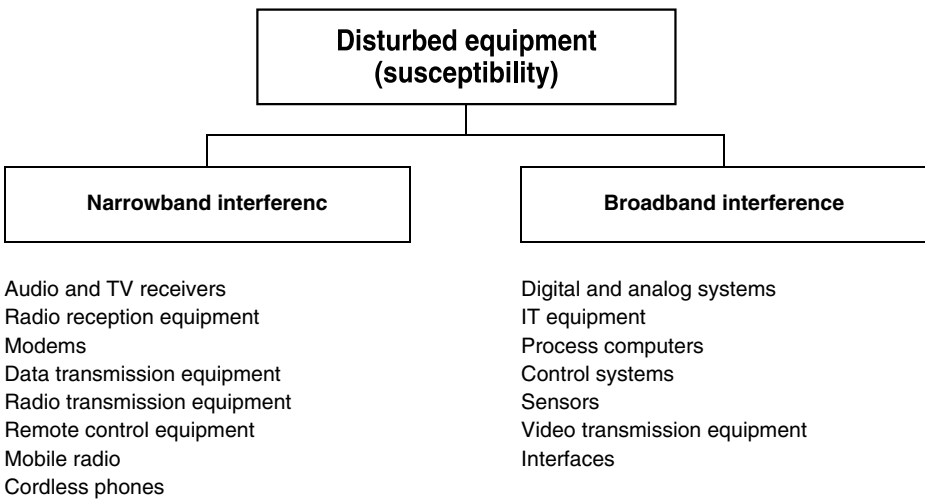

Figure 4 Interference sinks

### 1.5 Propagation modes

Interference voltages and currents are classified as common-mode, differential-mode and unsymmetrical disturbances:

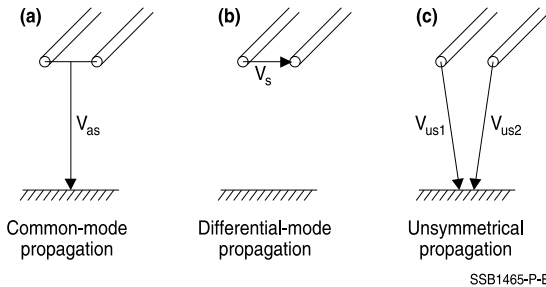

Figure 5 Propagation modes

- (a) = Asymmetrical or *common-mode* interference:  
interference between all lines of a cable and reference potential.  
It occurs principally at high frequencies (from about 1 MHz).
- (b) = Symmetrical or *differential-mode* interference:  
interference between two lines (L-L, L-N).  
It occurs principally at low frequencies (up to some 100 kHz).
- (c) = Unsymmetrical or *normal-mode* interference:  
Interference between a single line and reference potential.

### 1.6 Interference characteristics

In order to be able to choose the correct EMC measures, we need to know the characteristics of the interference, how it is propagated and the coupling mechanisms involved. In principle, any interference can also be classified according to its propagation mode (Figure 5). At low frequencies, it can be assumed that the interference spreads only along conductive structures, at high frequencies virtually only by means of electromagnetic radiation. In the immediate near-field region, the term coupling (capacitive or inductive) is generally used to describe this mechanism.

Analogously, conducted interference at frequencies of up to several hundred kHz is mainly differential mode (symmetrical), whereas it is common mode (asymmetrical) at higher frequencies. This is because the coupling factor and the effects of parasitic capacitance and inductance between the conductors increase with frequency.

X capacitors and all series inductors are suitable as differential-mode component. Common-mode interferences can be reduced by current-compensated chokes and Y capacitors. However, this requires a well-designed EMC-compliant earthing and wiring system.

## General technical information

The categorization of types of interference and suppression measures and their relation to the frequency ranges is reflected in the frequency limits for interference voltage and interference field strength measurements.

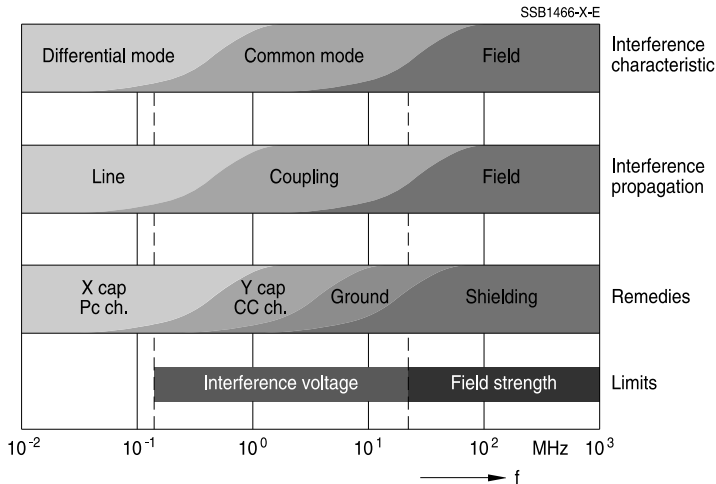

Figure 6 Frequency overview

Pc-ch. = Iron powder core chokes, but also all single chokes

X cap = X capacitors

CC-ch. = Current-compensated chokes

Y cap = Y capacitors

### 1.7 EMC measurement methods

As previously mentioned, an interference source causes both conducted and radiated electromagnetic interferences.

Propagation along lines can be detected by measuring the interference current and interference voltage (Figure 7).

The effect of interference fields on their immediate vicinity is assessed by measuring the magnetic and electric fields. This kind of propagation is also frequently termed electric or magnetic coupling (near field).

In higher frequency ranges, characterized by the fact that equipment dimensions and measuring distances are smaller than the wavelength under consideration, the interference energy is mainly radiated directly (far field). Conducted and radiated propagation must also be taken into consideration when testing the susceptibility of disturbed equipment. Interference sources such as sine-wave generators as well as pulse generators with a wide variety of pulse shapes are used for such tests.

**General technical information**

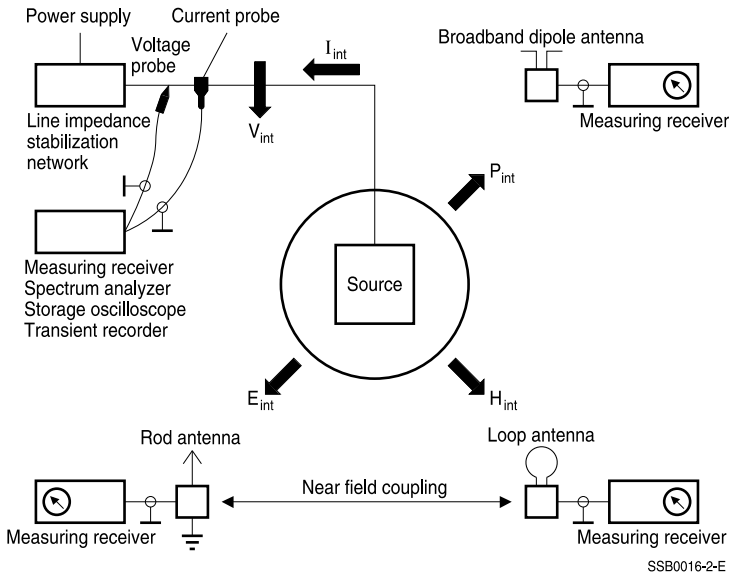

Figure 7 Propagation of electromagnetic interference and EMC measurement methods

- $H_s$  = Magnetic interference fields
- $E_s$  = Electric interference fields
- $P_s$  = Electromagnetic interference fields (far-field)
- $I_s$  = Interference current
- $V_{int}$  = Interference voltage

**1.8 EMC standards**

Harmonized European standards have been issued in conjunction with the EU's EMC Directive or national EMC legislation. These specify measurement methods and limits or test levels for both the emissions and immunity of electrical equipment, installations and systems.

The subdivision of the European standards into various categories (see following tables) makes it easier to find the rules that apply to the respective equipment. The generic standards apply invariably to all equipment. If the equipment is within the scope of a specific product family standard or dedicated product standard, these may be used for assessing the conformity. The basic standards contain information on interference phenomena and general measuring methods.

With the exception of the standards for harmonic and flicker assessment, they contain no limit specifications and are consequently not listed as harmonized standards in the EU's Official Gazette.



## General technical information

The following standards and specifications form the basis for the conformity tests:

EMC standards	Germany	Europe	World
---------------	---------	--------	-------

### Generic standards

define the EMC environment in which an equipment may be appropriately operated.

Emissions	Residential area	DIN EN 61000-6-3	EN 61000-6-3	IEC 61000-6-3
	Industrial area	DIN EN 61000-6-4	EN 61000-6-4	IEC 61000-6-4
Interference immunity	Residential area	DIN EN 61000-6-1	EN 61000-6-1	IEC 61000-6-1
	Industrial area	DIN EN 61000-6-2	EN 61000-6-2	IEC 61000-6-2

### Basic standards

contain physical phenomena and measuring methods.

Measuring equipment		DIN EN 55016-1-x	EN 55016-1-x	CISPR 16-1-x
Measurement methods	Emissions	DIN EN 55016-2-x	EN 55016-2-x	CISPR 16-2-x
	Immunity	DIN EN 61000-4-1	EN 61000-4-1	IEC 61000-4-1
Harmonics		DIN EN 61000-3-2	EN 61000-3-2	IEC 61000-3-2
		DIN EN 61000-3-12	EN 61000-3-12	IEC 61000-3-12
Flicker		DIN EN 61000-3-3	EN 61000-3-3	IEC 61000-3-3
		DIN EN 61000-3-11	EN 61000-3-11	IEC 61000-3-11
Immunity parameters, e.g.				
ESD		DIN EN 61000-4-2	EN 61000-4-2	IEC 61000-4-2
EM fields		DIN EN 61000-4-3	EN 61000-4-3	IEC 61000-4-3
Burst		DIN EN 61000-4-4	EN 61000-4-4	IEC 61000-4-4
Surge		DIN EN 61000-4-5	EN 61000-4-5	IEC 61000-4-5
Induced RF fields		DIN EN 61000-4-6	EN 61000-4-6	IEC 61000-4-6
Magnetic fields		DIN EN 61000-4-8	EN 61000-4-8	IEC 61000-4-8
Voltage dips		DIN EN 61000-4-11	EN 61000-4-11	IEC 61000-4-11

### Product family standards

contain limits for emissions and interference immunity.

ISM equipment	Emissions Immunity	DIN EN 55011 <sup>1)</sup>	EN 55011 <sup>1)</sup>	CISPR 11 <sup>1)</sup>
Domestic appliances	Emissions	DIN EN 55014-1	EN 55014-1	CISPR 14-1
	Immunity	DIN EN 55014-2	EN 55014-2	CISPR 14-2
Lamps	Emissions	DIN EN 55015	EN 55015	CISPR 15
	Immunity	DIN EN 61547	EN 61547	IEC 61547
Radio and TV equipment	Emissions	DIN EN 55013	EN 55013	CISPR 13
	Immunity	DIN EN 55020	EN 55020	CISPR 20
High-voltage equipment	Emissions	DIN VDE 0873	—	CISPR 18

1) Governed by the safety and quality standards of the product families.

## General technical information

EMC standards		Germany	Europe	World
ITE equipment <sup>2)</sup>	Emissions	DIN EN 55022	EN 55022	CISPR 22
	Immunity	DIN EN 55024	EN 55024	CISPR 24
Vehicles	Emissions	DIN EN 55025	EN 55025 <sup>3)</sup>	CISPR 25
	Immunity	—		ISO 11451 ISO 11452

The most important interference immunity standards are listed below.

Standard	Test characteristics	Phenomena
----------	----------------------	-----------

### Conducted interference

EN 61000-4-4 IEC 61000-4-4	5/50 ns (single pulse) 2.5 kHz, 5 kHz or 100 kHz burst	Burst (pulse packet) Cause: Switching processes
EN 61000-4-5 IEC 61000-4-5	1.2/50 $\mu$ s (open-circuit voltage) 8/20 $\mu$ s (short-circuit current)	Surge (high-energy transients), Cause: Lightning strikes on power lines, switching processes
EN 61000-4-6 IEC 61000-4-6	1; 3; 10 V 150 kHz to 80 MHz (230 MHz)	High-frequency coupling, narrowband interference

### Radiated interference

EN 61000-4-3 IEC 61000-4-3	3; 10 V/m 80 to 1000 MHz or to 6 GHz	High-frequency interference fields
EN 61000-4-8 IEC 61000-4-8	to 100 A/m 50 Hz	Magnetic interference fields with power frequencies

### Electrostatic discharges (ESD)

EN 61000-4-2 IEC 61000-4-2	to 15 kV	Electrostatic discharges
-------------------------------	----------	--------------------------

### Instability of the supply voltage

EN 61000-4-11 IEC 61000-4-11	e.g. 40 % $V_N$ for 1 ... 50 periods 0 % $V_N$ for 0.5 periods	Voltage dips Short-term interruptions
EN 61000-4-11 IEC 61000-4-11	e.g. 40 % $V_N$ or 0 % $V_N$ (2 s reduction, 1 s reduced voltage, 2 s rise)	Voltage fluctuations

2) Some equipment comes under the R&TTE Directive (Radio and telecommunications terminal equipment).

3) The EU directive on electromagnetic compatibility of motor vehicles 2004/104/EG also contains limits and Interference immunity requirements.

### 1.9 Propagation of conducted interference

In order to be able to select suitable EMC components and filters, the way in which conducted interferences are propagated needs to be known.

A floating interference source primarily emits differential-mode interference which is propagated along the connected lines (Figure 8). The interference current will flow towards the disturbed equipment on one line and away from it on the other line, just as the line current does.

Differential-mode interferences occur mainly at low frequencies (up to several hundred kHz).

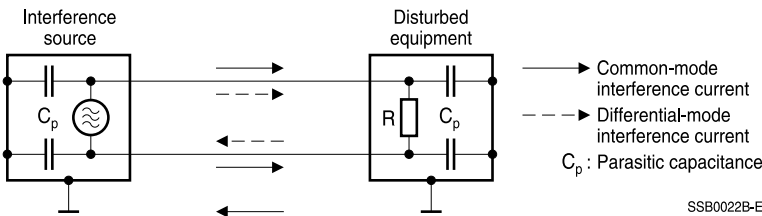

Figure 8 Common-mode and differential-mode interference

However, parasitic capacitances in interference sources and disturbed equipment or intended earth connections also produce an interference current in the earth circuit. This common-mode interference current flows towards the disturbed equipment along both the connecting lines and returns to the interference source through earth. Since the parasitic capacitances will tend to form a short-circuit with increasing frequencies and the undesired coupling effects on the connecting cables and the equipment itself will increase correspondingly, common-mode interferences become dominant above some MHz.

In addition to these two components, the term "unsymmetrical interference" is used to describe the interference voltage between one line and a reference potential at a defined impedance, and consists of symmetrical and asymmetrical parts.

EPCOS specifies characteristic values of insertion loss referred to a 50  $\Omega$  system for the individual filter types in order to facilitate the selection of suitable EMC filters.

### 1.10 Filter circuits and line impedance

EMC filters are virtually always designed as reflecting low-pass filters, i.e. they reach their highest trap attenuation when they are – on the one hand – mismatched to the impedance of the interference source and interference sink and – on the other hand – mismatched to the impedance of the line. Possible filter circuits for various impedance conditions of the line or interference source/sink are shown in Figure 9.

In order to implement optimum filter circuits and cost-effective solutions, it is useful to know the impedances involved, but these must be considered over the examined frequency range.

**General technical information**

The impedances of the power networks under consideration are known from calculations and extensive measurements, whereas the impedances of interference sources or disturbed equipment are, in most cases, unknown or known only inadequately.

For this reason, it is impossible to design the most suitable filter solution without EMC tests. In this context, we offer our customers the consulting services of our competent staff, both on-site and in our EMC laboratory in Regensburg/Germany (see also "EMC services", Section 7 "EMC laboratory").

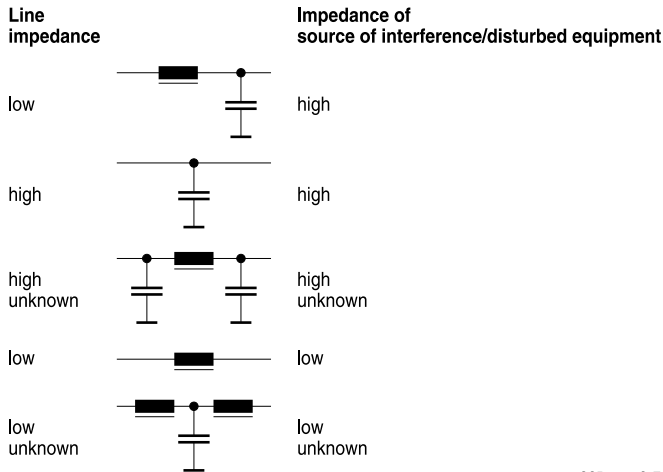

SSB0042-Q-E

Figure 9 Filter circuit and impedance

## 2 Selection criteria for EMC filters

To comply with the currently applicable regulations, a frequency range of 150 kHz to 1000 MHz, in some cases also up to several GHz, has to be taken into consideration, in most cases, in order to ensure electromagnetic compatibility; in addition, however, further aspects such as low-frequency system perturbations should be considered.

EMC filters must thus have good RF characteristics and are usually required to be effective over an extremely broad frequency range.

- For individual components (inductors, capacitors), the RF characteristics are specified by stating the impedance as a function of frequency.
- The insertion loss is used as a criterion for selecting EMC filters (see Section 3.1.17).

If the device under test (DUT) is terminated on both sides with a resistive impedance of 50  $\Omega$ , for example, the result of the measurement is referred to as being the 50- $\Omega$  insertion loss. Priorities for considering the three possible kinds of insertion loss, namely

- asymmetrical (common mode),
- symmetrical (differential mode) and
- unsymmetrical

must be decided upon depending on the desired application.

The measuring method for 50- $\Omega$  insertion loss has been adapted from the field of communications engineering and is also specified in the relevant national and international standards.

Although it permits a comparison of different filters, it provides only little information on the efficiency of the filter in practical applications.

The reason is – as already mentioned in the previous section – that neither the interference source, the disturbed equipment nor the connected power line system will have a resistive impedance of 50  $\Omega$  at frequencies below 1 MHz.

Likewise, the attenuation of interference pulses cannot simply be determined on the basis of the insertion loss curve. In this case, it is also necessary to take the non-linear response of the EMC chokes in the filters into consideration.

Filter-specific values may be quoted upon request if you send us the pulse shapes in question.

## General technical information

### 3 Terms and definitions

#### 3.1 Electrical characteristics

##### 3.1.1 Rated voltage $V_R$

The rated voltage  $V_R$  is either the maximum RMS operating voltage at the rated frequency or the highest DC operating voltage which may be continuously applied to the filter at temperatures between the lower category temperature  $T_{min}$  and the upper category temperature  $T_{max}$ . Filters which are rated for a frequency of 50/60 Hz may also be operated at DC voltages.

##### 3.1.2 Nominal voltage $V_N$

The nominal voltage  $V_N$  is the voltage which designates a network or electrical equipment and to which specific operating characteristics are referred. IEC 60038 defines the most widely used nominal voltages for public supply networks (e.g. 230/400 V, 277/480 V, 400/690 V). It is recommended that the voltage at the transfer points should not deviate from the nominal voltage by more than  $\pm 10\%$  under normal network conditions.

##### 3.1.3 Difference between rated and nominal voltage

For filters and chokes, the rated voltage is defined as a reference parameter. It specifies the maximum voltage at which the filter can be continuously operated (see Section 3.1.1). This voltage must never be exceeded, as otherwise damage may occur. Only small deviations are tolerated, such as may occur when a filter or choke with a rated voltage of 250 V is operated in a network with a nominal voltage of 230 V ( $230\text{ V} + 10\% = 253\text{ V}$ ). This relationship is shown in Figure 10.

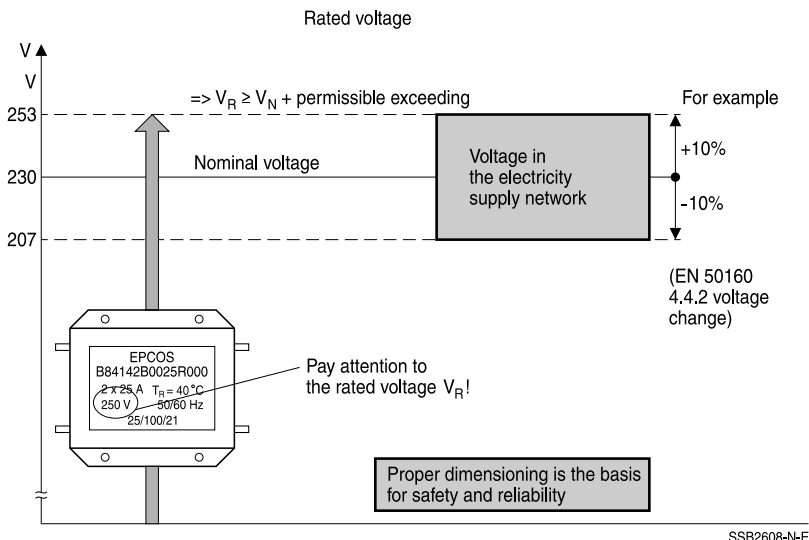

Figure 10 Difference between rated and nominal voltage

## General technical information

Care should be taken when selecting EMC filters and other EMC components not to exceed the respective maximum line voltage, e.g.  $V_N + 10\%$ . Brief overvoltages are permitted to EN 60939.

### 3.1.4 Network types

The filters are approved for various network types (e.g. TN, TT, IT network). The various network types are described in Section 7 "Energy supply networks".

### 3.1.5 Test voltage $V_{\text{test}}$

The test voltage  $V_{\text{test}}$  is the DC or AC voltage applied to the filter or choke in the final production test (item test) for the specified test duration. If required, we recommend a single repetition of the voltage test at max. 80% of the specified value. A rate of voltage rise or drop of 500 V/s should not be exceeded. The time must be measured as soon as 90% of the test voltage permissible for the test has been reached. No dielectric breakdown should occur during the test (the insulation would no longer limit the current flow). Capacitor healing effects are permissible.

### 3.1.6 Rated current $I_R$

The rated current  $I_R$  is the highest DC or AC current at which the filter or choke can be continuously operated under the rated conditions.

Above the rated temperature  $T_R$ , the operating current should as a rule be reduced according to the derating curves (see Section 10 "Current derating"). In 2- and 3-line filters and chokes, the rated current refers to the concurrent loading of all lines with the specified value. In 4-line filters (e.g. filters with three phase lines and one neutral line), the sum current of the neutral line is considered to be close to zero.

In the event of operation with non-sinusoidal AC currents, divergences from sinusoidal currents may produce higher thermal loads, which must be considered. The temperature increase of the filters and chokes at their rated current and temperature is measured by connecting them via test cross-sections on the basis of UL 508 "Industrial Control Equipment" (largely similar to IEC 60947-1).

### 3.1.7 Overload

The rated current may be briefly exceeded. Exact data on the permissible currents and stress duration are given in the various data sheets.

### 3.1.8 Pulse load

Exposure to high-energy pulses can lead to saturation effects (e.g. in the ferrite cores used). This can reduce their interference suppression effect. A measure of the pulse load capability of chokes and filters is their maximum permissible voltage time area. As a guide value for standard filters, the range from 1 to 10 mVs can be assumed. More precise data is available upon request.

### 3.1.9 Current derating $I/I_R$

At ambient temperatures above the rated temperature specified in the data sheet, the operating current for filters and chokes must be reduced in line with the derating curves (see Section 10.1 "Current derating at ambient temperatures exceeding the rated temperature").

## General technical information

### 3.1.10 Rated inductance $L_R$

The rated inductance  $L_R$  is the inductance specified for a particular choke. It is measured at a frequency  $f_L$ .

### 3.1.11 Stray inductance $L_{Scat}$

The stray inductance  $L_{Scat}$  is the inductance measured at a unilateral short circuit of both windings of a current-compensated choke (Figure 11). It acts on differential-mode interference.

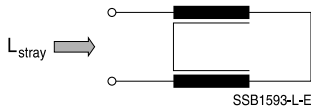

Figure 11 Stray inductance

### 3.1.12 Inductance decrease $\Delta L/L_0$

The inductance decrease  $\Delta L/L_0$  is the relative drop in inductance at the specified current, where  $L_0$  is the inductance without a current load. The specifications in some data sheets (other than EPCOS) are given in percent. The drop is caused by the magnetization of the core material by the operating current as a function of the field strength.

### 3.1.13 DC resistance $R_{typ}$ , $R_{min}$ , $R_{max}$

The DC resistance is the line resistance measured with DC at an ambient temperature of 20 °C. The test current should be selected to be significantly lower than the rated current.

$R_{typ}$	Typical value
$R_{min}$	Minimum value
$R_{max}$	Maximum value

### 3.1.14 Winding capacitance, parasitic capacitance $C_p$

Depending on the geometry of the filter, parasitic capacitances  $C_p$  occur which impair the RF properties. These capacitances can occur both between the lines (differential mode) and between the lines and earth (common mode). The EMC filters from EPCOS are configured to minimize the parasitic effects. They consequently have an outstanding interference suppression effect even at high frequencies.



## General technical information

### 3.1.15 Q-factor

The Q-factor is defined as the ratio of the imaginary and real parts of the impedance measured at a frequency  $f_Q$ .

### 3.1.16 Test frequencies $f_Q$ , $f_L$

$f_Q$  is the frequency at which the Q-factor of a choke is measured.

$f_L$  is the frequency at which the inductance of a choke is measured.

### 3.1.17 Insertion loss

The insertion loss is a measure of the efficiency of filters and components. The test procedure used to measure the interference suppression properties was updated in the IEC publication CISPR 17 in 2011 and was published as the EN 55017 standard.

Measurement principle:

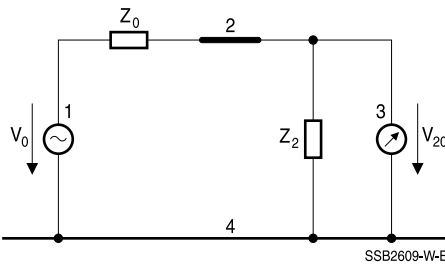

Figure 12 Test circuit for insertion loss; filter replaced by short circuit

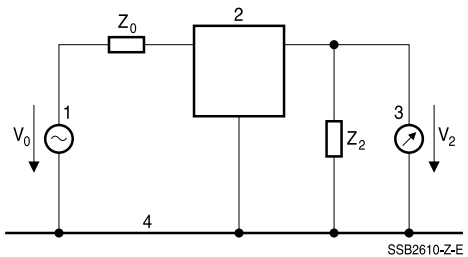

Figure 13 Test circuit for insertion loss; measurement of the EMC filter

#### Legend

- 1 Signal generator
- 2 EMC filter (DUT)
- 3 Test receiver
- 4 Reference potential (metallic test surface)
- $V_0$  Open-circuit generator voltage
- $V_2$  Output voltage
- $V_{20}$  Output voltage (with short circuit)
- $Z_0$  Generator impedance
- $Z_2$  Impedance of the receiver

Definition of the insertion loss in dB:

$$\alpha_e = 20 \log \frac{V_{20}}{V_2} = 20 \log \frac{V_0}{2V_2}$$

With the following simplification:

$$Z_0 = Z_2 = 50 \Omega \text{ and thus } V_{20} = \frac{V_0}{2}$$

**Test circuits for measuring the insertion loss in EMC filters**

a) Symmetrical measurement (differential mode) exemplified by a 4-line filter

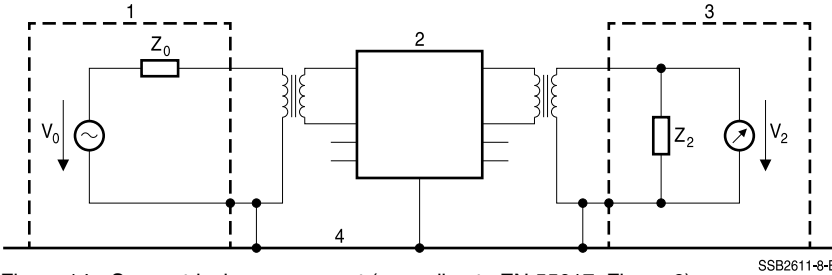

SSB2611-G-E

Figure 14 Symmetrical measurement (according to EN 55017, Figure 6)

Every possible line pair is connected via isolating transformers (ratio 1:1), with the unused lines remaining unconnected.

b) Asymmetrical measurement (common mode) exemplified by a 4-line filter

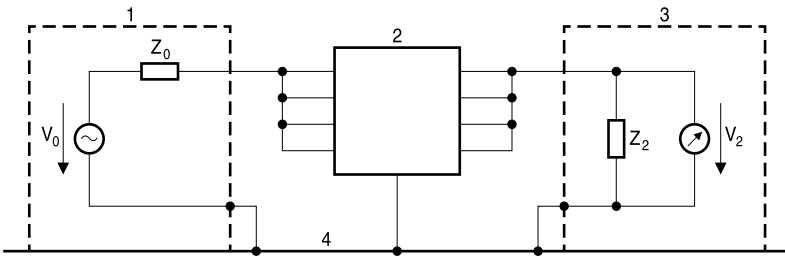

SSB2612-G-E

Figure 15 Asymmetrical measurement (according to EN 55017, Figure 5)

All input and output lines are connected to each other for the measurement.

c) Unsymmetrical measurement (normal mode) exemplified by a 4-line filter

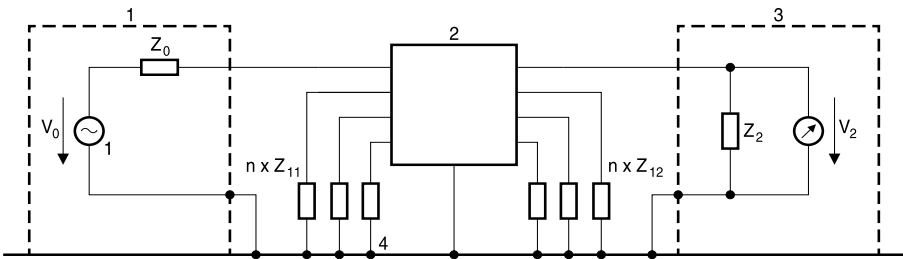

SSB2613-P-E

Figure 16 Unsymmetrical measurement (according to EN 55017, Figure 7)

Each line pair is measured, the unused lines being terminated with a defined impedance (usually 50 Ω).

General technical information

Insertion loss in applications

As a rule, the previously described test circuits use impedance values of 50 Ω. In a few cases, the measurements are also specified with impedances of 0.1 Ω and 100 Ω. However, the actual impedances occurring in the application diverge significantly from the test impedances.

The reference network, derived from a three-phase 4-line network, is defined in EN 61000-3-3 as follows:

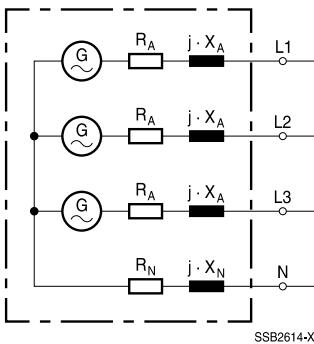

Figure 17 Equivalent circuit diagram of the reference network

Where  $R_A = 0.24 \Omega$ ;  $jX_A = 0.15 \Omega$  (@ 50 Hz);  $R_N = 0.16 \Omega$ ;  $jX_N = 0.10 \Omega$  (@ 50 Hz).

The insertion loss curves shown in the Data Book thus have an informative character in order to allow various filters to be quantified and compared. A precise evaluation can only be achieved by measuring the interference voltage in the active application.

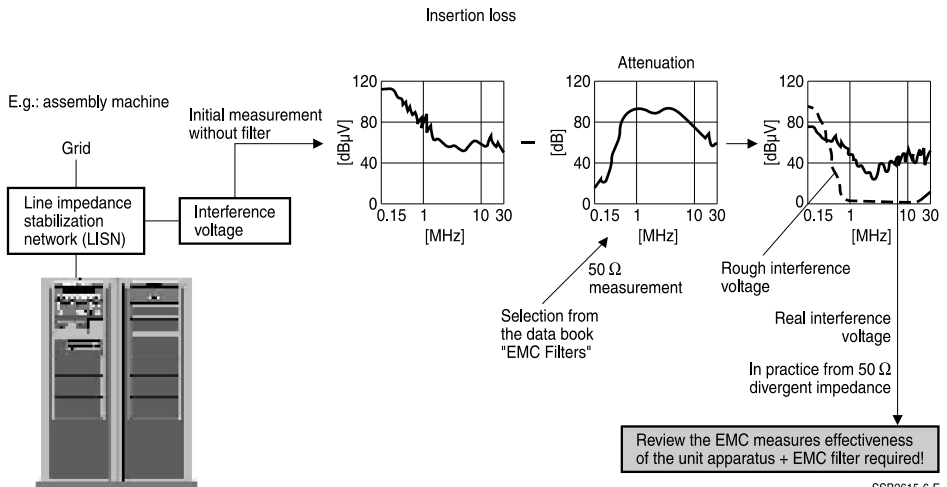

Image 18 Insertion loss in practice

### 3.1.18 Leakage current

A detailed description with calculation examples and safety notes may be found in Section 8 "Leakage current".

### 3.1.19 Discharge resistors

Discharge resistors ensure that the energy stored in the capacitors drops to low values within a short time, so that the voltage applied to the terminals drops to below the permissible values (see also Section 6 "Safety regulations").

### 3.1.20 Finger protection

The EMC filter is designed so that with the use of suitable terminals any contact with the fingers is excluded in the event of clamped leads with a usual cross section for the rated current. Protection level IP2X to IEC 60529 is then assured. This provides protection against the penetration of solid foreign bodies of diameter  $\geq 12.5$  mm as well as preventing persons from touching hazardous parts with their fingers. In practice, a jointed test finger of 12 mm diameter and 80 mm length must be sufficiently distant from hazardous parts.

### 3.1.21 KU value

**Term:** The KU value is a classification parameter of safety-referred failure types designed to assure protection against hazardous body currents and excessive heating, e.g.

- in insulations and insulating components for the short-circuit fault type,
- in connections and connecting components for die interruption fault type.

The KU value applies under defined operating conditions.

**Explanations:**

- KU values are subdivided into the following stages: 0; 1.5; 3; 4.5 and 6.
- KU = 6 means that no danger is assumed to be present.
- At voltages and currents above the low-voltage limits, protection measures must reach a value of KU = 6.
- Specific values may be found in DIN VDE 0800-9. Some examples are given below:
  - Y capacitors; short circuit KU = 3; interruption KU = 1.5
  - X capacitors; short circuit, interruption KU = 1.5
  - Metal-layer resistors (climate, Q-factor confirmation and surge voltage test); short circuit, interruption KU = 3
  - Permanently fixed  $\geq 1.5$  mm<sup>2</sup> leads according to the conditions for protection leads; interruption KU = 4.5
  - $\geq 10$  mm<sup>2</sup> leads with connection type run to the requirements of PEN leads; interruption KU = 6
- The application of the KU values is illustrated in DIN VDE 0800-8.
- As pointed out in the explanation of the DIN VDE 0800-1 standard, this procedure for determining safety techniques (exemplified by telecommunication technologies) may also be applied to installations and equipment. The DIN VDE 0800 series of standards fulfils an important bridging function between the safety standards for setting up electrical installations and the standards for the construction and testing of electrical equipment.

## General technical information

### 3.1.22 Referred voltage drop of a choke in %: $u_k$

$$u_k = \frac{V_k}{V_N} \cdot 100 \% \quad \text{where} \quad \begin{array}{l} V_k = \text{Voltage drop of the choke} \\ V_N = \text{Nominal voltage} \end{array}$$

The voltage drop of a choke may be approximately calculated as follows:

$$X_L = 2 \cdot \pi \cdot f \cdot L \quad \text{where} \quad \begin{array}{l} f = \text{Frequency (for Data Book specification of 50 Hz)} \\ L = \text{Rated inductance of the chokes} \end{array}$$

$$V_R = p \cdot V_N \quad \text{where} \quad \begin{array}{l} V_R = \text{Rated voltage} \\ p = \text{Factor for voltage tolerance 1.1 (e.g. typical tolerance } \pm 10\%) \end{array}$$

For 1-phase chokes:

$$V_k = I_R \cdot X_L \quad \text{where} \quad I_R = \text{Rated current}$$

For 3-phase chokes in the symmetrical three-phase network

$$V_k = I_R \cdot X_L \cdot \sqrt{3}$$

*Example for 3-phase power choke B86305L0230S000:*

$$\begin{array}{ll} L = 0.15 \text{ mH} & \Rightarrow X_L = 2 \cdot \pi \cdot 50 \text{ Hz} \cdot 0.15 \cdot 10^{-3} \text{ H} = 47.1 \text{ m}\Omega \\ I_R = 230 \text{ A} & \Rightarrow V_k = 230 \text{ A} \cdot 47.1 \cdot 10^{-3} \Omega \cdot \sqrt{3} = 18.8 \text{ V} \end{array}$$

## 3.2 Mechanical properties

### 3.2.1 Encapsulation (economy and full)

A distinction is made between economy and full encapsulation.

Economy encapsulation is used to mount the various filter components in the casing. This process is cost-effective, as the encapsulation can be carried out in a single step. It is therefore used in many EMC filters from EPCOS.

Full encapsulation is necessary either when the heat dissipation achieved with economy encapsulation is insufficient, or the customer has special requirements.

## General technical information

### 3.2.2 Winding types

Filters from EPCOS use chokes with outstanding technical properties. All chokes have precisely reproducible and optimized RF properties and are matched to the respective application (e.g. saturation behavior with pulses). In this way and thanks to their construction, the filters have reproducible properties with respect to their effectiveness (e.g. insertion loss).

In line with the technical requirements, chokes with various winding configurations are used. The different winding types lead to different properties of the inductors, especially in the RF range:

- *Single-layer winding*

This winding configuration has the lowest capacitance and thus the highest resonant frequency compared to the other winding types.

- *Multi-layer winding*

This winding configuration has the highest capacitance and thus the lowest resonant frequency compared to the other winding types.

- *Random winding*

### 3.2.3 Recommended tightening torques for screw connections – reference values

Most EMC filters from EPCOS have metallic casings. The screw mounting is used for mechanical fixing and simultaneously sets up, via the casing contact, the large-area connection to the earth potential (see also Chapter "Mounting instructions"). A distinction must be made here between the functions of mechanical fixing, earth connection and the PE connection to ensure protection against excessive contact voltages.

For the standard screw connections to the filter and choke attachment, we refer to state-of-the-art solutions, as the tightening torques depend on the nominal size, length, strength class, corrosion protection and lubricants. It should be noted for face-side press nuts mainly for EMC-compliant assembly that additional attachments are needed for filter weights >10 kg. In all cases, the equipment installer must check its strength with respect to loads (e.g. vibrations, impacts).

Unless stated otherwise in the data sheets, we recommend the tightening torques shown in the following tables.

Recommendation for tightening torques for press nuts/press bushings:

Nominal size of press nuts	Tightening torque in Nm (tolerances for setting values)
M 4	1.5 ( 1.43 ... 1.58)
M 5	3.0 ( 2.85 ... 3.15)
M 6	5.1 ( 4.90 ... 5.40)
M 8	12.6 (12.00 ... 13.20)

## General technical information

### Screw connections via PE threaded bolts

For current-carrying and PE terminals on 2-, 3- and 4-line filters contacted via threaded bolts, we recommend the following tightening torques:

Nominal size of threaded bolts	Tightening torque in Nm (tolerances for setting values)
M 4	1.2 ( 1.10 ... 1.30)
M 5	2.0 ( 1.90 ... 2.10)
M 6	3.0 ( 2.85 ... 3.15)
M 8	6.0 ( 5.70 ... 6.30)
M 10	10.0 ( 9.00 ... 11.00)
M 12	15.5 (14.00 ... 17.00)

For tightening torques for feedthrough capacitors and filters, see the introductory text to the chapter on "Feedthrough components".

### Screw connections of busbars

For some filters and chokes with rated currents >100 A, aluminum or copper busbars are used as connection elements.

We recommend the following materials for busbar screw connections according to DIN 43673-1:

Part	Recommendation
Busbar	Copper
Screw	Strength class 8.8 or higher according to DIN EN ISO 898-1; Corrosion protection tZn (hot-galvanized)
Nut	Strength class 8 or higher according to DIN EN ISO 898-2; Corrosion protection tZn (hot-galvanized)
Spring element on screw and nut side	Spring washer according to DIN 6796; corrosion-protected
Lubricant	Based on MoS <sub>2</sub>

To ensure the required area pressure, we recommend the following tightening torques:

Nominal size of threaded bolts	Tightening torque in Nm
M 8	15
M 10	30
M 12	60

All electrical contact points must be uncoated and thinly greased with technical vaseline (for electrical contacts). We recommend fine-grained Scotch Brite™ fiber pads for cleaning the contact surfaces.

## General technical information

### 3.2.4 General tolerances

The data part of this Book contains dimensional diagrams for each filter or chokes. The following points should be noted:

- All dimensional specifications in mm
- 1 inch corresponds to 25.4 mm, and 1 mm corresponds to 0.03937 inches; accuracy 5 digits after the decimal point
- Linear and angular dimensions without individual tolerance indication have tolerance class "c" to ISO 2768-1.
- Geometrical tolerances for features without individual tolerances indications have tolerance class "L" to ISO 2768-2.

Limits for linear measures (values in mm):

Tolerance class	Limits for nominal sizes								
c (coarse)	< 0.5	0.5 ... 3	> 3 ... 6	> 6 ... 30	> 30 ... 120	> 120 ... 400	> 400 ... 1000	> 1000 ... 2000	> 2000 ... 4000
	<sup>4)</sup>	± 0.2	± 0.3	± 0.5	± 0.8	± 1.2	± 2	± 3	± 4

4) For nominal sizes < 0.5 mm the limit measures are to be indicated directly at the nominal measure.

General tolerances for straightness and evenness (values in mm):

Tolerance class	Range for specified size					
L	≤ 10	> 10 ... 30	> 30 ... 100	> 100 ... 300	> 300 ... 1000	> 1000 ... 3000
	0.1	0.2	0.4	0.8	1.2	1.6

General tolerances for symmetry (values in mm):

Tolerance class	Range for specified size			
L	≤ 100	> 100 ... 300	> 300 ... 1000	> 1000 ... 3000
	0.6	1	1.5	2



## General technical information

### 3.3 Climatic characteristics

#### 3.3.1 Upper and lower category temperatures $T_{\max}$ and $T_{\min}$

The upper category temperature  $T_{\max}$  and the lower category temperature  $T_{\min}$  are defined as the highest and lowest ambient temperatures respectively at which the filter or choke can be continuously operated.

#### 3.3.2 Rated temperature $T_R$

The rated temperature  $T_R$  is the highest ambient temperature at which the filter or choke can be operated at its rated current.

#### 3.3.3 Standard climate for tests

Unless otherwise defined, all tests and measurements should be carried out in standard climates to IEC 60068-1, Chapter 5.3:

- Air temperature 15 °C ... 35 °C
- Relative air humidity 25% ... 75%
- Air pressure 86 KPa ... 106 KPa (860 mbar ... 1060 mbar)

#### 3.3.4 IEC climate category

The climatic usability of components is defined by the climate category to IEC 60068-1, Annex A. It is formed by three defining parameters separated by slashes. These parameters are the temperatures applied for the tests with cold and dry heat and the stressing duration with moist constant heat.

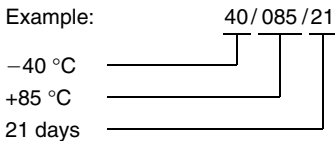

##### First defining parameter:

Absolute value of the lower category temperature  $T_{\min}$  as the test temperature for test Ab (cold) to IEC 60068-2-1 for 16 h.

##### Second defining parameter:

Absolute value of the upper category temperature  $T_{\max}$  as the test temperature for test Bd (dry heat) to IEC 60068-2-2 for 16 h

##### Third defining parameter:

Stressing duration in days for test Cab (moist heat, constant) to IEC 60068-2-78 at 40 °C; testing accuracy - relative air humidity 85% or 93% depending on the specification.

## General technical information

In addition, further type tests to IEC 60939 are used for EMC filters depending on the specifications and properties, e.g.:

- Heating (determining the filter temperature when stressed with the rated current and at the rated temperature)
- Overcurrent
- Temperature cycling stresses
- Pulse strength

At customer request, we also examine the resistance of the filters to other environmental effects in special laboratories:

- test Ka (salt spray) to IEC 60068-2-11
- test Ke (corrosion test with flowing mixed gas) to IEC 60068-2-60
- test Db (moist heat, cyclic) to IEC 60068-2-30.

### 3.4 Transport and storage conditions

The transport and storage conditions for electronic products must be observed so that the delivered goods retain the same properties they had at the time of dispatch.

Transport and storage conditions:

- Transport and storage in the original packaging at temperatures of -25 ... +40 °C.
- Relative air humidity 75% as an annual average and 95% on up to 30 days.
- Aggressive atmospheres or dew formation are not permissible.
- Observe the temperature gradient of 20 K/h.

The specified processability is two years from the date of manufacture. This applies particularly to filters and chokes with solder terminals, in order to ensure solderability. Divergent conditions will be tested by EPCOS for permissibility upon request. Please contact your local distributor or EPCOS salesperson when required.

### 3.5 Legal and administrative terms

The EU directives and the national laws derived from them make use of some key terms which may diverge somewhat from their current everyday use. The main terms from EMC Directive 2004/108/EC of 15.12.2004 as well as from the EU's "Blue Guide" (Guide to the implementation of directives based on the New Approach and the Global Approach) are therefore summarized below. Additional terms and explanations may be found in the relevant EU directives or in the "Blue Guide".

#### 3.5.1 Equipment (EMC Directive)

"Equipment" designates an item of apparatus or a fixed installation.

#### 3.5.2 Apparatus (EMC Directive)

"Apparatus" means any finished appliance or combination thereof made commercially available as a single functional unit, intended for the end user and can produce electromagnetic interference or whose functionality/operation can be impaired by electromagnetic interference.

## General technical information

The term "apparatus" in the sense of the EMC Directive also applies to:

- a) "Components" or "sub-assemblies" intended for incorporation into an apparatus by the end user, which are liable to generate electromagnetic disturbances, or the performance of which is liable to be affected by such disturbance;
- b) "Mobile installations" defined as a combination of apparatus and, where applicable, other devices, intended to be moved and operated in a range of locations.

### 3.5.3 Fixed installations (EMC Directive)

"Fixed installation" means a particular combination of several types of apparatus and, where applicable, other devices, which are assembled, installed and intended to be used permanently at a predefined location.

### 3.5.4 Manufacturer (Blue Guide)

A manufacturer in the sense of the new concept is the one who is responsible for the design and manufacture of a product which is brought onto the market in his name in the European Union (EU). The manufacturer is obligated to ensure that a product that is to be brought onto the EU market is designed and manufactured in line with the key requirements contained in the regulations of the applicable directives issued on the basis of the new concept, and is subject to a conformity assessment.

The manufacturer may use ready-made products, parts or elements, or assign work to subcontractors. However, he must always retain the overview and have the necessary authorizations in order to assume responsibility for the product.

The manufacturer is also anyone who produces new equipment from ready manufactured end products or significantly changes, reconstructs or adapts new equipment with respect to its electromagnetic compliance.

### 3.5.5 Placing in the market and putting into service (Blue Guide)

Placing in the market is the first-time entry of a product, at cost or at no cost, onto the EU market for sale or use within the area of the EU.

Putting into service implies the first use of the equipment by the end user in the area of the EU. However, the necessity to assure within the scope of the market overview that the products satisfy the stipulations of the directive at the time of putting into operation is restricted.

If a product is put into circulation on the EU market for the first time and put into service, it must satisfy the applicable directives issued on the basis of the new concept.

Placing in the market thus refers to the individual item of equipment to which this directive applies, irrespective of the time and place of manufacture and of whether it was manufactured in single or series production. Putting into circulation does not refer to the setting up and presentation of an item of equipment at exhibitions and trade fairs.

## General technical information

### 4 Safety test marks

International harmonization of the relevant standards is the common aim of most countries. International standards (IEC) are often implemented in European (EN) and national standards (e.g. DIN EN for Germany). For EMC filters, IEC 60939 was implemented as EN 60939 and DIN EN 60939. This created the basis for standardizing the product tests.

The ENEC mark, which is now over 20 years old, replaced the earlier usual national test marks. It certifies the agreement of the product with the European standards, especially regarding safety.

For use on the North American market, many of our filters carry the UL or CSA test mark. A filter additionally approved by the US certification authority UL for the Canadian market carries the UL and cUL test marks or the combined cULus test mark.

The safety test marks issued for a filter are listed in the data sheets.

Our filters are listed under the following file numbers by the test organizations:

Organization	File number	Standard
VDE	40405-4730-*	EN 60939
UL	E70122	UL 1283
	E320370	UL 1446
CSA	LR54258	CSA C22.2 No.8

Europe:



ENEC 10

North America:



UL  
USA



CSA  
Canada



cUL  
Canada



cULus  
USA/Canada

## 5 CE conformity mark

### 5.1 What is the CE mark?

The CE mark is a conformity mark for the European Economic Area (formulated in various directives). It confirms the agreement of a product with the directives applicable within the single European market. Initially, however, it must be noted what the CE mark is not:

- The CE mark is **not a test mark**
- The CE mark is **not a certification mark**
- The CE mark is **not a safety mark**
- The CE mark is **not issued** by an independent third party

The CE mark is attached to the product, with some exceptions, by the manufacturer at his own responsibility after determining the conformity with the protection requirements set out in the EU directives. On the basis of the new approach, these directives only contain the general stipulations regarding the protection targets to be observed. Their main aim is not to endanger the safety of human beings and animals as well as material property (Low Voltage Directive, Article 2).

### 5.2 No CE mark for components

The buyers of electronic components repeatedly urge the use of the CE mark. However, this implies the erroneous assumption that the use of CE-marked parts guarantees that a CE-compliant equipment is produced, so that proof of conformity of the equipment can be either completely avoided or at least considerably simplified. The wish "not to do anything wrong" also leads occasionally to the call for CE-marked components. This overlooks the fact that the component manufacturer cannot guarantee the level of protection required by the directives, despite every care, even for components certified by third parties (EMC capacitors, inductors and filters).

The tests only allow the safety of the components to be assessed under standardized test conditions, which in the nature of things can cover only a part of the loads occurring in practice. This cannot in any case cover faults in the construction of an item of equipment or in its production phase.

This leads unavoidably to the manufacturer's responsibility for any equipment used directly by the end user. He alone can assess, test and ultimately certify its conformity, i.e. any marking of individual parts is irrelevant to the conformity status of the end product.

The free availability of parts to everyone on the wholesale and retail markets is often mentioned as a criterion for marking. This is certainly correct for many freely available products, as these can be used directly by the buyer (= end user), for instance domestic appliances, electrical tools, extension parts for equipment such as graphics cards or hard disks for PCs. However, this argument does not apply to electronic components, as the buyer cannot use them directly. They are used either as spares for repairs or to build new equipment (hobbyists, amateur radio operators).

## General technical information

In every case, however, there is no need to act as regards safety in the sense of the directives as long as the components are not further processed. These activities are unequivocally designated in the EU directives as manufacturing, i.e. all private persons who act in a do-it-yourselfer or repair capacity are also considered to be manufacturers and hence are obliged to test the resulting (new or modified) products for their conformity.

### 5.3 Conclusions

All the arguments presented here, especially the "spirit of the law", which translates the intentions of the originators of the CE marking and the EU directives, agree with the view of the components industry that the CE-marking of

- passive components (such as capacitors, inductors, resistors, filters) and
- semiconductors (such as diodes, transistors, triacs, GTOs, IGBTs, integrated circuits, micro-processors)

is impermissible.

## General technical information

### 6 Safety regulations

In the manufacture of our components we always aim to satisfy the highest safety requirements. However, the diverse applications of our customers mutually exclude certain requirements. Thus some applications need high insulating resistors (e.g. insulation monitoring), whereas others require the permissible residual voltages to be considered.

#### 6.1 Protection against residual voltages

 IEC 60204 and EN 50178 require that active parts must be discharged within a period of 5 s to a voltage below 60 V (or 50  $\mu\text{C}$ ). If this requirement cannot be observed in view of the operating mode, the hazardous site must be permanently marked in a clearly visible way. This must be done by means of an appropriate text as well as by graphical symbols, such as "Hazardous electrical voltage" (417-IEC-5036) and "Caution" (7000-ISO-0434). Exposed cables of connectors must have a discharge time of 1 s, or else degree of protection IP2X or IPXXB (IEC 60529) must be ensured.

The safety requirements "Protection by limiting the discharge energy" in Annex EN 50178 must also be observed. The 50  $\mu\text{C}$  limit specified there is below the threshold for ventricular fibrillation. The values determined by the capacitor voltage  $V_C$  and the capacitance  $C$  according to EN 50178, Annex A.5.2.8.2, Table A.1 (see table below) should be used for exposed active parts. Calculations and/or measurements should be carried out for the test.

*Values for the exposed capacitance and load voltage (pain threshold):*

Capacitor voltage $V_C$ V	Capacitance nF	Capacitor voltage $V_C$ V	Capacitance nF
70	42400	500	18
78	10000	700	12
80	3800	1000	8
90	1200	2000	4
100	580	5000	1.6
150	170	10000	0.8
200	91	20000	0.4
250	61	40000	0.2
300	41	60000	0.133
400	28		

As the filters are in most cases connected permanently with the installation part and are thus connected to other low-resistance loads, these requirements are as a rule observed.

The manufacturer of the installations or equipment is obliged to check the circumstances of the application and to take any necessary measures.

## General technical information

### 6.2 Discharge resistors

⚠ The EMC filters manufactured by EPCOS are supplied with internal high-resistance discharge resistors (unless otherwise requested by the customer). However, their connection alone does not as a rule fulfill the requirements of all the relevant standards, regulations and specifications, but simply discharges the capacitance within a specific time period.

In the case of filters that are not permanently connected (e.g. when applying a test voltage at the incoming goods inspection), a discharge must be carried out after turning off the voltage. To reduce the leakage currents, circuit variants with a star-shaped configuration of the X capacitors and connection of Y capacitors from the virtual star point are used. The discharge can then lead to internal charge shifts between the capacitors, i.e. a voltage >60 V may result between the phase and casing or PE. To avoid this, a low-resistance connection should be set up immediately after the discharge from the casing or PE terminal to the voltage-carrying filter terminals. The safety specifications must be observed.

For customer-specific filters, discharge resistors may also be inserted between phase and casing upon request. Special discharge resistors are then used at voltages and currents above the rated class 3<sup>5)</sup> which satisfy the requirements for the KU values<sup>6)</sup> for safety-relevant components. The required KU value of 6 (DIN VDE 0800-1) is then reached for the total system. However, a high insulation resistance can no longer be assured in this case.

### 6.3 EMI suppression capacitors

EMC filters from EPCOS contain EMI suppression capacitors according to EN 60384-14 for operation at AC line voltages. These capacitors are divided into two classes (Class X and Class Y).

Class X is designed for applications whose failure cannot lead to hazardous electrical shock (typically capacitors between the phases). Class X is subdivided into sub-classes X1, X2 and X3 according to the peak pulse voltage reached in operation.

Class	Voltage strength	Peak pulse voltage in operation	Application	Pulse test
X1	4.3 V <sub>R</sub>	2.5 kV < V <sub>s</sub> ≤ 4.0 kV	Use at high peak voltages	4.0 kV <sup>7)</sup>
X2	4.3 V <sub>R</sub>	V <sub>s</sub> ≤ 2.5 kV	General requirements	2.5 kV <sup>7)</sup>
X3	4.3 V <sub>R</sub>	V <sub>s</sub> ≤ 1.2 kV	General requirements	none

In applications where failure of the capacitor could lead to a hazardous electric shock, capacitors of Class Y are used (typically capacitors between phase and casing). In line with the type of bridged insulation, the rated voltage range and the peak voltage value, a subdivision is made into subclasses Y1, Y2, Y3 and Y4.

5) The rated class is a range of current and voltage values from which the same physiological effects can be expected in a contact current circuit (DIN VDE 0800-1)

6) The KU value is a classification parameter of safety-referred failure types designed to ensure protection against hazardous body currents and excessive heating (DIN VDE 0800-1).

7) For C<sub>R</sub> ≤ 1 μF see also EN 60384-14.



## General technical information

Class	Type of bridged insulation	Voltage strength	Pulse test	Rated voltage range
Y1	Double or reinforced insulation	4.0 kV AC	8.0 kV	$V_R \leq 500 \text{ V}$
Y2	Basic or additional insulation	1.5 kV AC	5.0 kV	$150 \text{ V} < V_R \leq 300 \text{ V}$
Y3	Basic or additional insulation	1.5 kV AC	none	$150 \text{ V} < V_R \leq 250 \text{ V}$
Y4	Basic or additional insulation	0.9 kV AC	2.5 kV	$V_R \leq 150 \text{ V}$

### 6.4 Mounting and dismantling the filters

When mounting and dismantling our filters, we recommend observation of the rules that apply generally for the operation of electrical equipment. This includes setting up and ensuring a no-voltage state and observing the five safety rules described in EN 50110-1.

The following steps should be carried out in the specified sequence unless important reasons require a divergence from this sequence:

- Disconnect
- Ensure that no reconnection is possible
- Ensure that no voltage is present
- Earthing and short-circuiting<sup>8)</sup>
- Cover or separate adjacent live parts.

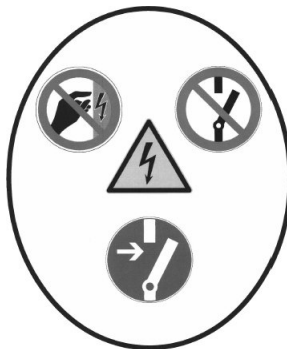

Figure 19 Pictograms for work protection

<sup>8)</sup> In low-voltage installations, earthing and short-circuiting are not necessary, unless the risk exists that a voltage may be applied to the installation (e.g. second feed).

## General technical information

### 7 Energy supply networks

#### 7.1 Function of the networks

- |    |   |  |
|----|---|--|
| A) | Transmission network:                           | Extra-high voltage (220 kV, 380 kV ... approx. 1200 kV)<br>High voltage (60 kV ... 150 kV) |
| B) | Distribution to regional transformer stations:  | Medium voltage (1 kV ... 20 kV ... 30 kV)  |
| C) | Local distribution (e.g. households, industry): | Low voltage (e.g. 230 V, 400 V, 690 V)   |

This Data Book exclusively concerns current supply systems with low voltages. The voltage limit is defined here as 1000 V AC or 1500 V DC.

 The rated voltages specified for three-phase systems apply to the TN-S networks with symmetrically earthed star points usual in Europe! In the case of divergent network types, please check the suitability of the filters and the observance of the permissible voltages inclusive of possible fault cases such as earth faults or triggering of overcurrent protection equipment by other than all poles. In cases of doubt, contact the TDK EPCOS specialists, who will advise you in your specific filter application.

#### 7.2 Designation of distribution systems (IEC 60364-1)

##### TN-S

Third letter:

Configuration of neutral conductor and protective conductor (if present)

S = The protection function is set up by a conductor which is separated from the neutral conductor or earthed line conductor.

C = Neutral and protective conductors are combined in a single conductor (PEN conductor)

Second letter:

Earthing of the equipment

T = Direct connection of the equipment with earth

N = Direct connection of the equipment with earthed point of the power supply system (usually star point or earthed line)

First letter:

Connection of the power supply system to earth

T = Direct connection of a pole to earth

I = System is separated from earth or earthed via the impedance

**General technical information**

**7.3 TN system**

TN systems are directly earthed; the parts of the equipment to be earthed are connected to this point via protective conductors.

Three types of TN systems may be distinguished:

- TN-S system: A separated protective conductor is used in the whole system.
- TN-C system: The functions of the neutral and protective conductors are combined in a single conductor (PEN) in a part of the system.
- TN-C-S system: The functions of the neutral and protective conductors are combined in a single conductor (PEN) in the whole system.

**7.3.1 TN-S system with star current source and separated neutral and protective conductors**

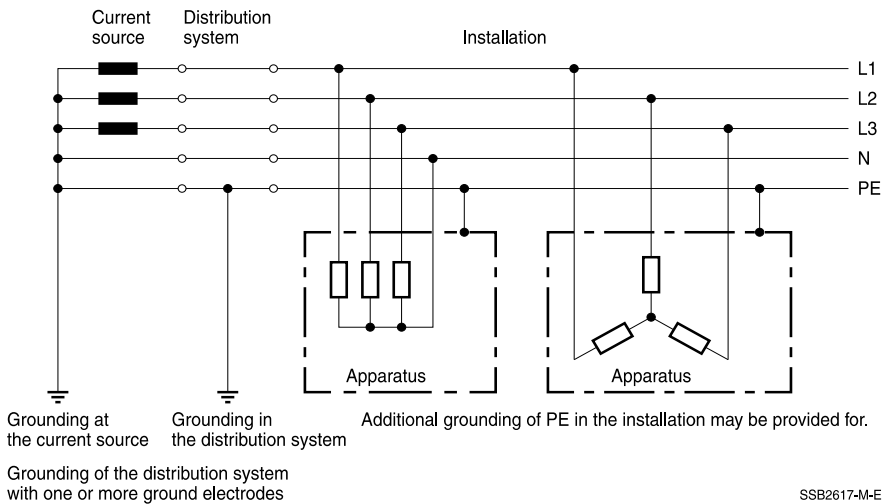

Figure 20 TN-S system star with separated protective conductor

### 7.3.2 TN-S system with delta current source and earthed line conductor

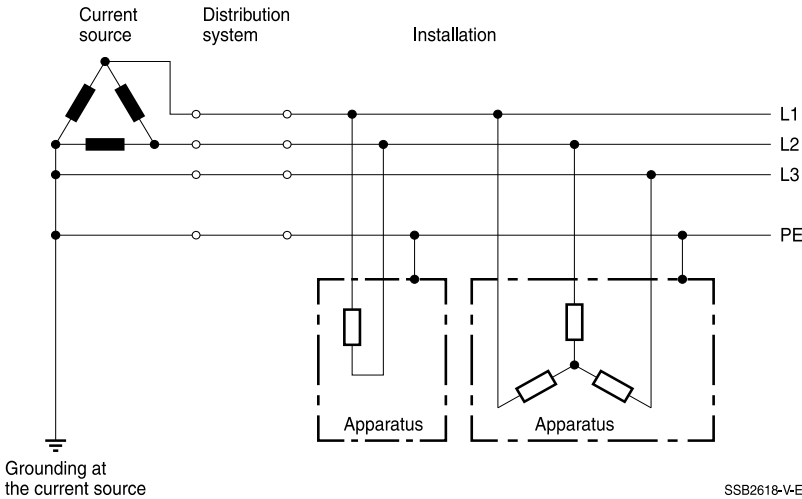

Figure 21 TN-S system delta with earthed line conductor

### 7.3.3 TN-C system with star current source; neutral and protective conductor functions combined (PEN)

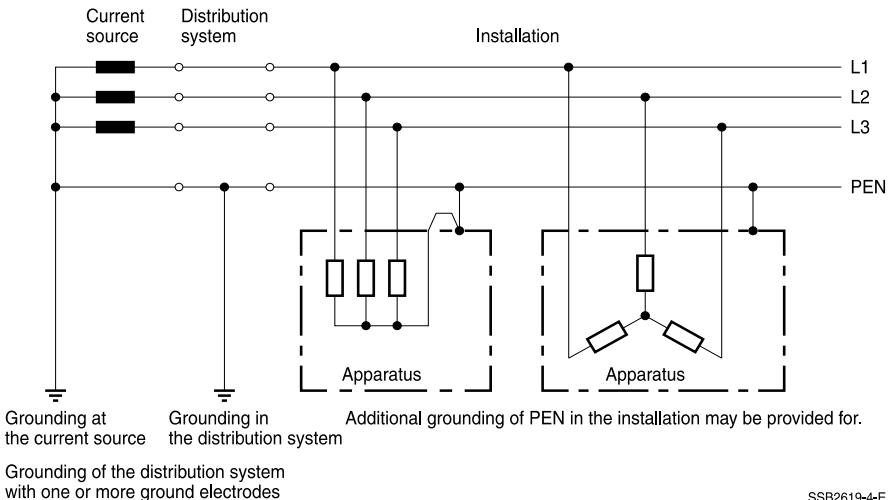
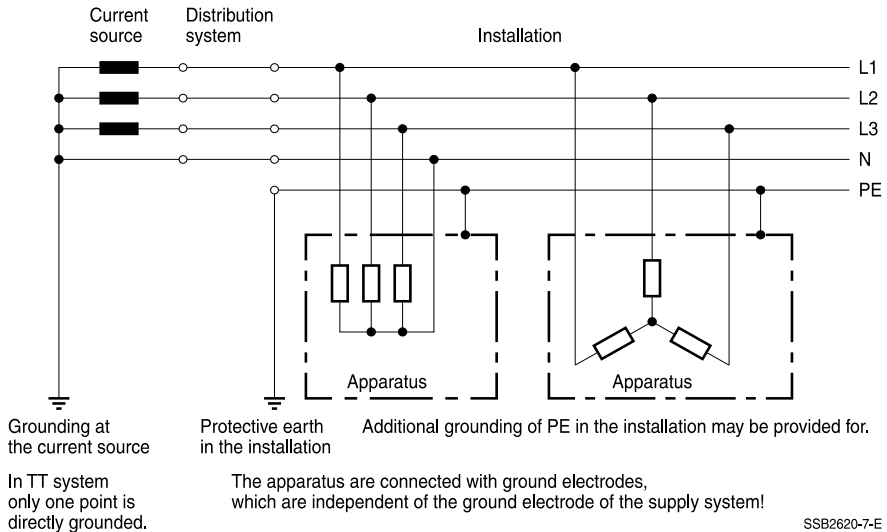

Figure 22 TN-C system with star current source; neutral and protective conductor functions combined (PEN)

### 7.4 TT systems

TT systems are directly earthed at a point. The parts of the equipment to be earthed are connected at the load location with earth, separated electrically from the earthing elements of the power supply network.



SSB2620-7-E

Figure 23 TT system

## 7.5 IT systems

IT systems are separated from earth, but a point can be earthed via an impedance or a voltage limiter. The equipment to be earthed is connected at the load location with earthing elements.

### 7.5.1 IT system with star current source and neutral conductor

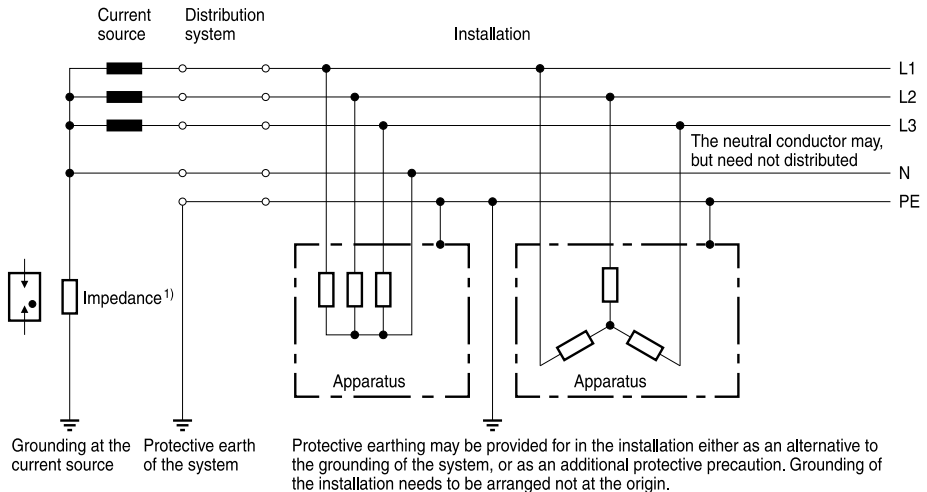

<sup>1)</sup> The system may be connected with ground about a high impedance. This connection may be done, e.g., in the mid-point or artificial mid-point or line conductor. Grounding of the IT system over a sufficiently high impedance is applied in Germany only for measurement and functional purposes.

SSB2621-F-E

Figure 24 IT system star with neutral conductor

### 7.5.2 IT system with delta current source

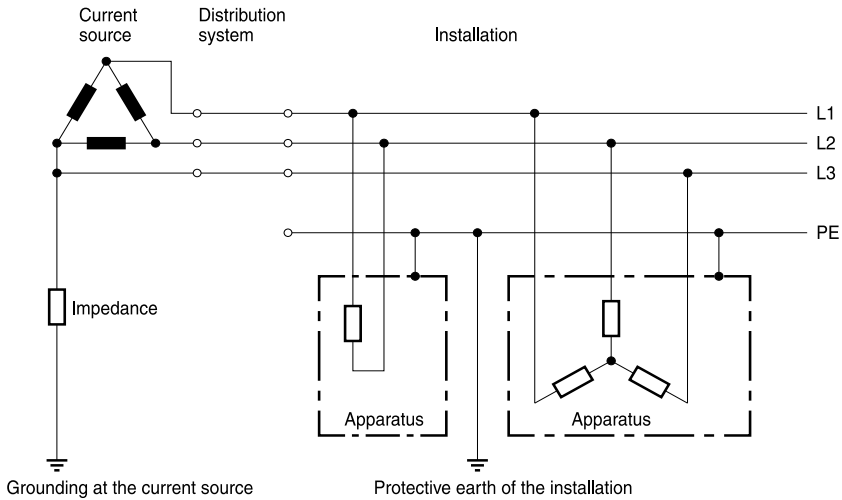

SSB2622-N-E

Figure 25 IT system delta

The notes and comments from Figure 24 apply in principle. The system can be unearthed at the current source.

### 7.6 Special features of the IT system

**⚠** In an IT system, a short circuit of a line conductor with respect to earth may be of long-term duration (conditions and duration as per the equipment specification), for instance to complete an ongoing process (e.g. newspaper printing machines). This short circuit is described as a **"first fault case"**. When using EMC filters, this leads to two problems:

If the first fault case occurs between the supply (line side) and the filter, a connection is made to earth by the external short circuit of one of the X capacitors in the filter, and thus parallel to the Y capacitor (see Figure 27). The shift of the star point leads to a voltage increase across the other X-capacitors and the combination X/Y capacitor. This can lead to the capacitors being overloaded if the filter is not rated for this load. Our filters released for IT systems are designed for this first fault case.

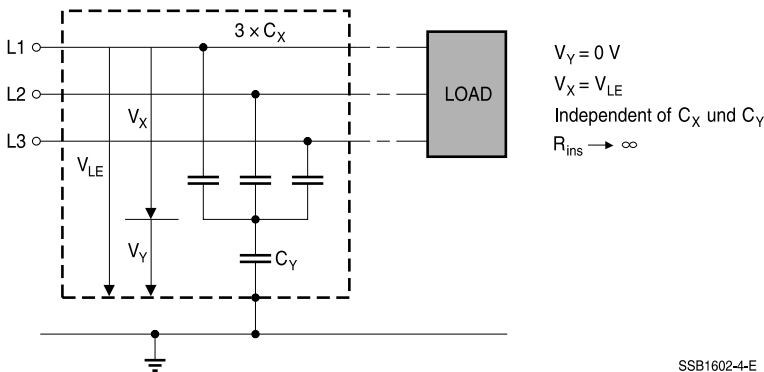

Figure 26 Normal operation

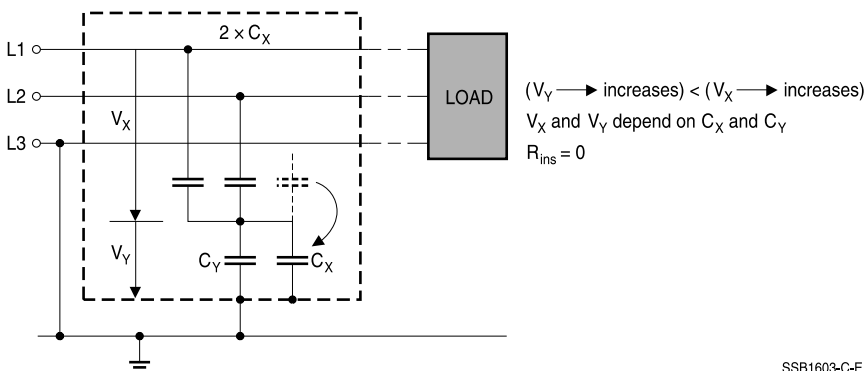

Figure 27 First fault case (earth connection of a conductor)



## General technical information

However, if the first fault case occurs between the converter and motor, the output voltage is connected directly to earth and thus to the Y capacitors of the filter (see Figure 28). The high  $dv/dt$  of the converter output (several  $kV/\mu s$ ), which also occurs in fault-free operation, can lead to an excessive current flowing through the Y and X capacitors and damaging the filter. Such damage may also occur with active recovery converters in the event of an earth connection on the converter input side.

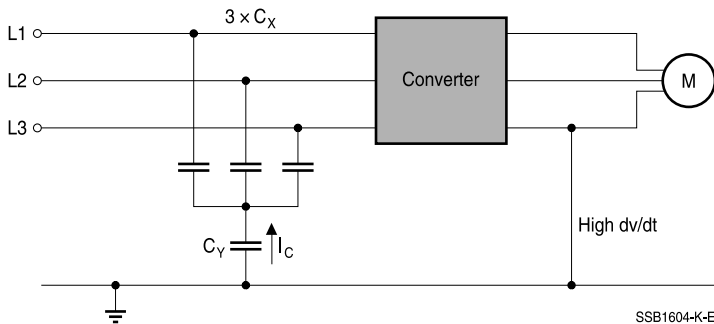

Figure 28 First fault case between converter and motor

Our EMC filters are not designed for this and all other fault cases. However, if all boundary conditions are known, some filters can be released for this purpose by the EPCOS filter developers.

### 7.7 Suitability of filters for IT systems

The filters of the B84143B\*S024 series may also be used in IT systems as long as the operating conditions specified in the Data Book are satisfied.

These filters remain functional in an IT system

- in the event of a line-side short circuit of a line conductor with respect to earth (excepting recovery-capable converters),
- at the specified operating voltage (see the rated voltage in the data sheet as well as on the filter typeplate) and
- normal network quality (see EN 50160).

For statements about the reliability of these filters in a special application case in an IT system, the possible boundary conditions of operation and fault cases must be precisely known or specified by the user. Since the application-specific requirements on an IT system can vary greatly (e.g. short circuit at converter output), we cannot make any general statements of extensive validity. For special requirements, however, we are happy to assist our customers in an advisory and supportive capacity.

The same applies to the risks of using these filters for both filters and equipment. These can in principle only be estimated when the boundary conditions are known.

## General technical information

Only a single high-resistance connection is permissible in an IT system. Thanks to its Y capacitors, an effective interference suppression filter already forms this permissible connection to earth (see also EN 61800-3, Annex D.2).

The line-side short circuit of an line conductor with respect to earth is permissible on our IT-system filters. All other faults can lead to damage of the equipment and the filter.

Statements about

- the  $dv/dt$  between conductors as well as between the conductors and earth,
- the duration, frequency and combination of the fault conditions and
- the type of equipment

are relevant for the release or development of filters for special conditions of use.

The leakage currents of the filters can trigger an earth fault monitoring circuit even in the absence of a fault case.

## 8 Leakage current

### 8.1 General definition

Leakage current (in a system): "the current which flows to earth or to an external conductive part in a fault-free circuit."

This definition may still be found in the German DIN VDE 0100-200 standards (terms) and supplement. Unfortunately, the use of terms leakage current, contact current and protective conductor current in the standards is no longer unequivocal.

In general, the term leakage current is the generic term for all types of leakage currents:

- Touch current  $I_T$  (electric current through the human body, when this body touches one or more accessible parts); its most important effects are distinguished, namely perception, reaction, let-go and burn.
- Protective conductor current  $I_{PE}$  (current flowing through the protective conductor during normal operation).
- I-partial current  $I_{IT}$  (current flowing via the insulation).

Except for the introduction, EN 60950-1 and the corresponding measurement methods in EN 60990 cover only the touch and protective conductor currents.

 Please note the divergent definition of the patient leakage current and its limits according to IEC 60601-1 for medical applications.

### 8.2 Definition of filter leakage current $I_{LK}$

The following applies to all information contained in the Data Book:

The filter leakage current  $I_{LK}$  is the current flowing through the protective conductor or the metal casing of the filter (usually through the interference suppression capacitors connected to earth). The specified filter leakage current refers exclusively to the filter and differs from the leakage current of the equipment or system.

In the data sheets, the filter leakage current is designated in brief as the leakage current  $I_{LK}$ . It is specified as a calculated value according to IEC 60939-1 Annex A. This calculation method assures the comparability of different filters. The actual leakage current in applications cannot be specified, as it depends on many parameters such as voltage asymmetry and harmonic content. The calculated value of the filter leakage current  $I_{LK}$  is purely theoretical and does not represent a maximum value which takes into account all the possibilities of the network conditions and the maximum component tolerances.

### 8.3 Calculation method for the filter leakage current $I_{LK}$

Please note that:

The filter leakage current  $I_{LK}$  is added to the leakage currents (such as the parasitic capacitances of cables, motor windings, etc.) of other loads and of the equipment or installation! The calculation formulas given below are taken from Annex 1 of the IEC 60939-1 standard. They refer to systems with no loads connected to the filter output.

**General technical information**

**8.3.1 Calculation of filter leakage current  $I_{LK}$  for 1-line filters**

The filter leakage current is obtained from the ratio of the rated voltage and the capacitive impedance to ground.

$$I_{LK} = 2 \cdot \pi \cdot f_R \cdot V_R \cdot C_Y$$

- $I_{LK}$  Filter leakage current
- $f_R$  Rated frequency
- $V_R$  Rated voltage
- $C_Y$  Nominal capacitance to ground

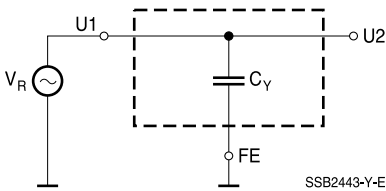

Figure 29 Leakage current for 1-line filters

**8.3.2 Calculation of filter leakage current  $I_{LK}$  for 2-line filters**

The filter leakage current is obtained from the ratio of the rated voltage and the capacitive impedance of a Y capacitor.

$$I_{LK} = 2 \cdot \pi \cdot f_R \cdot V_R \cdot C_Y$$

- $I_{LK}$  Filter leakage current
- $f_R$  Rated frequency
- $V_R$  Rated voltage
- $C_Y$  Nominal capacitance to ground

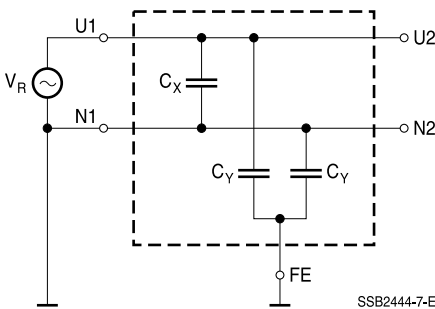

Figure 30 Leakage current for 2-line filters

### 8.3.3 Calculation of filter leakage current $I_{LK}$ for 3-line filters

The filter leakage current is obtained from the ratio of the voltage between the capacitor neutral point and reference earth and the capacitive impedance of the Y capacitor. The standard defines a voltage difference between the phases of 6%, which corresponds approximately to a voltage unbalance of 2%.

$$I_{LK} = 2 \cdot \pi \cdot f_R \cdot V_{NM} \cdot C_Y = 2 \cdot \pi \cdot f_R \cdot \frac{0.06 \cdot V_R \cdot C_X}{3 \cdot C_X + C_Y} \cdot C_Y$$

$$C_X = C_{X1} = C_{X2} = C_{X3}$$

- $I_{LK}$  Filter leakage current
- $f_R$  Rated frequency
- $V_R$  Rated voltage
- Phase to ground
- $V_{NM}$  Resulting voltage
- Neutral point to ground
- $C_X$  Nominal capacitance to star point
- $C_Y$  Nominal capacitance to ground

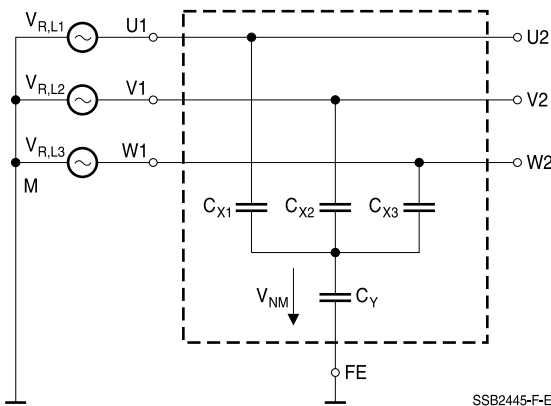

Figure 31 Leakage current for 3-line filters

### 8.3.4 Calculation of filter leakage current $I_{LK}$ for 4-line filters

The filter leakage current is obtained from the ratio of the voltage between the neutral conductor and ground and the capacitive impedance of the Y capacitor. As the neutral conductor and reference ground are connected at the supply transformer, the expected potential differences between them are small; the standard defines a value of 10 V across the board.

$$I_{LK} = 2 \cdot \pi \cdot f_R \cdot V_{NM} \cdot C_Y$$

$$V_{NM} = 10 \text{ V}$$

- $I_{LK}$  Filter leakage current
- $f_R$  Rated frequency
- $V_{NM}$  Voltage, neutral to ground
- $C_Y$  Nominal capacitance to ground

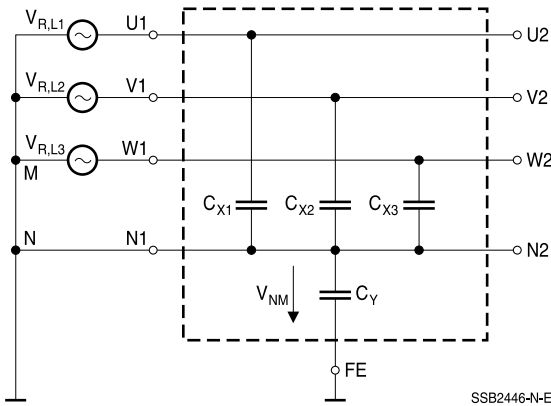



Figure 32 Leakage current for 4-line filters

## 8.4 Safety notes relating to leakage currents

 Bear in mind that the maximum leakage current of the electrical equipment or installation as a whole is limited for safety reasons. The applicable limits for your application may be obtained from the relevant specifications, regulations and standards.

As a rule, the following principles apply. However, some equipment specifications may involve divergent requirements, and different country-specific regulations may apply. You must check these out for your specific application. We would be pleased to offer you professional advice in this matter.

- Before putting the equipment in operation, first connect the protective conductor to the filter casing.
- Connect the protective conductor according to DIN VDE 0100-540.
- At leakage currents  $I_L^{(9)} \geq 10$  mA, a fixed connection between the protective conductor and the load network is required. A connection via connectors is consequently impermissible. Any measures taken to prevent excessive contact currents must have a KU value of 6.<sup>10)</sup>  
 KU = 6 with respect to interruptions is achieved with fixed conductors  $\geq 10$  mm<sup>2</sup>, where the connection type and running conform to the specifications for PEN conductors according to DIN VDE 0100-540.
- For stationary equipment of protection class I (fixed or with industrial connectors) and a leakage current  $I_L^{(9)} \geq 10$  mA, a KU value of 4.5<sup>10)</sup> should be reached for the protective conductor connection.  
 KU = 4.5 with respect to interruptions is reached:
  - With permanently connected protective conductor connections  $\geq 1.5$  mm<sup>2</sup>
  - With a protective conductor connection  $\geq 2.5$  mm<sup>2</sup> via connectors for industrial equipment (IEC 60309-2).
- When fault current circuit breakers are used, the leakage current of the total equipment or system maximum must not exceed half the rated triggering current of the protective device.

## 8.5 Limit values for leakage currents

For touch currents, the limits for perception and reaction are usually the most important, as the values for let-go and burn are usually higher. When measuring protective conductor currents, care should be taken to use a low-impedance measuring device and ensure a non-arithmetic summation of the protective conductor currents of the individual parts of the ramified earthing system.

Two examples of leakage current limits from the relevant standards are shown below. In all cases, the standards and specifications relating to the application must be observed. Thus the standards for medical equipment often have lower limit levels.

9)  $I_L$  = Leakage current - let-go

10) KU value (symbol KU) is a classification parameter for safety-referred failure modes designed to assure protection against hazardous body currents and excessive heating (DIN VDE 0800-1, 800-8, 800-9).

## General technical information

### 8.5.1 Electrical appliances for household and similar use according to EN 60335-1

Protection class		Appliance type; Connection type	(Leakage current <sup>11)</sup> ) Touch current Perception and reaction
Class	Explanation		
0	Appliances with basic insulation without protective conductors	–	0.5 mA
0I	Appliances with basic insulation without protective conductors, but with protective conductor terminals	–	0.5 mA
I	Appliances with protective conductors	Mobile	0.75 mA
		Stationary motor devices	3.5 mA
		Stationary heating appliances	0.75 mA or 0.75 mA/kW Max. rated current 5 mA
II	Appliances with double or reinforced insulation without protective conductors	–	0.25 mA
III	Devices with low safety voltage (SELV)	–	0.5 mA

11) According to EN 60990 Figure 4: Test circuit for touch current, rated for perception and reaction



## General technical information

### 8.5.2 Requirements for systems and equipment with a rated frequency of 50 or 60 Hz according to EN 61140

Current-using equipment	Equipment operating current	Maximum protective conductor current
With connectors $\leq 32$ A	$\leq 4$ A	2 mA
	7 A but $\leq 10$ A	0.5 mA per A of rated current
	10 A	5 mA
With connectors $> 32$ A or permanently connected or fixed (no special measures for the protective conductor)	$\leq 7$ A	3.5 mA
	$> 7$ A but $\leq 20$ A	0.5 mA per A of rated current
	$> 20$ A	10 mA
Permanently connected with PE conductor $\geq 10$ mm <sup>2</sup> Cu (or 16 mm <sup>2</sup> Al) or Connection of two PE conductors via separate terminals with standard cross section	–	$\leq 5\%$ of the rated current of the line conductor

## 8.6 Comments on the practical handling of the leakage current

For users of EMC filters, the question arises as to how to evaluate the specified filter leakage current. At the beginning of the section on the leakage current, this term ( $I_{LK}$ ) was defined for EMC filters from EPCOS. The calculation according to IEC 60939-1 Annex A provides a basis for better comparability of filter leakage currents. A calculation of the leakage currents under specific application conditions (voltage imbalance, harmonic range, voltage level) may be provided upon request.

As far as is technically possible and reasonable, low leakage current circuits are used in many EPCOS filters. This is a technically optimized solution for the user which produces a leakage current close to zero in a three-phase TN-S system at the same phase-earth voltages and exactly identical capacitance values. In practice, the capacitors naturally have a capacitance tolerance. However, EPCOS uses interference suppression capacitors from leading manufacturers whose production technologies assure a very low scatter width for this parameter. The characteristics of public electricity supply networks (EN 50160) are defined such that 95% of the time the phase-neutral voltage difference does not exceed 6%.

The magnitude of the leakage current of a filter depends not only on the circuit and the nominal capacitance values, but also on the voltage unbalance and the harmonic content of the network at the time of the measurement, as well as on the capacitance tolerance and its distribution in the circuit. So the measured value applies only to the filter at the specific time of measurement. In the application, these currents through the Y capacitors depend not only on the properties of the filter but also on the environment, i.e. the adjacent equipment and systems. Especially for converter applications, the low-frequency component of the leakage current becomes less important than the asymmetrical current caused by the clocked output voltage.

Although the leakage current was defined for a fault-free circuit (see Section 8.1 "General definition"), its magnitude is also a measure of the risk incurred by human beings by touching conductive parts if a PE conductor is interrupted. Depending on the magnitude of the measured leakage current, therefore, specific measures are required, such as suitably run protective conductors of higher reliability. See also Section 8.4 "Safety notes relating to leakage currents".

## General technical information

Below is an example of measurements made on three EMC filters from different production series of type B84143B0050R110 in an industrial TN-S network (400V/230V, 50 Hz) and in a synthetic network.

Power supply and time of measurement	Measurement of 3 filters from different production lots <sup>12)</sup>				Data Book
	Touch current according to EN 60990			Differential current <sup>13)</sup>	Filter leakage current $I_{LK}$ according to data sheet mA
	Unweighted	Perception and reaction	Let-go		
	mA	mA	mA	mA	
Industrial network time 1	2.14 ... 2.22	1.82 ... 1.86	1.56 ... 1.58	12.05 ... 12.50	3.1
Industrial network time 2	2.14 ... 2.18	1.76 ... 1.82	1.44 ... 1.50	11.82 ... 12.27	
Industrial network time 3	2.06 ... 2.10	1.72 ... 1.76	1.40 ... 1.44	11.36	
Synthetic network	0.22 ... 0.28	0.20 ... 0.27	0.20 ... 0.27	0.30 ... 0.41	

The example shows that the tolerance of the measured values of filters from three production lots is very low, indicating the consistently high production quality of EPCOS filters. The harmonic content of the industrial network leads to differences to the synthetic network in the order of magnitude of a power of ten. The filter leakage current specified in the Data Book for this filter corresponds approximately to the measured values in the industrial network and thus assures a sufficient safety margin.

**⚠ The filter leakage current specified in the Data Book is intended merely as a guide for users. Every specific application must be checked for compliance with the limits stated in the applicable standards with respect to the interaction between all components! For permanently connected equipment with protective conductor currents > 10 mA, a fixed protective conductor connection of at least 10 mm<sup>2</sup> Cu (or 16 mm<sup>2</sup> Al) or two conductors of standard cross section connected to separate terminals is required.**

<sup>12)</sup> Measurement by testing laboratory

<sup>13)</sup> Vector sum of the momentary currents flowing through all active conductors at the line-side input (L1, L2, L3); assessed as a function of frequency (measured with leakage current meter 5SZ9 300 from Siemens).

## 9 Voltage derating for EMC filters

### 9.1 General information

EMC filters are designed for operation at the rated voltage and frequency specified in the data sheet. This assumes an almost sinusoidal line voltage whose harmonic components lie within the limits approved by the power utilities.

Appropriate voltage derating must be applied where necessary to any higher voltages occurring in operation at frequencies higher than the rated frequency. They may be due to low-frequency system perturbations or voltage peaks generated by system resonances, such as may be caused by the clock frequency of an inverter in the network.

### 9.2 Theoretical relationships

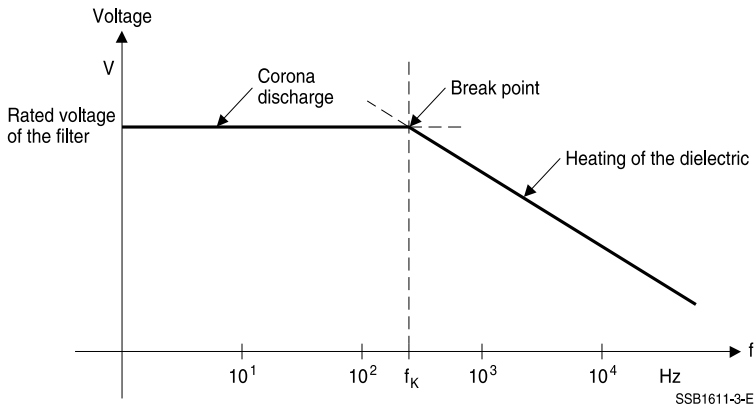

Figure 33 Theoretical relationships for voltage derating in filters

The maximum permissible voltage at the filter depends mainly on two limiting phenomena:

- The horizontal line in the area up to  $f_K$  represents the limit due to the corona discharge.
- Above  $f_K$ , the permitted voltage declines with the frequency, the curve represents the permitted maximum voltage for any particular frequency. If the voltage lies exactly on the curve, the maximum permissible self-heating of 10 K is reached.

In practice, several frequencies are applied to the filter (such as the harmonics of the switching frequency). To obtain the total heating and thus to determine whether the filter is still operated in its permissible operating range, all voltage amplitudes at each frequency must be calculated as described below.

## General technical information

### 9.3 Calculation of the permissible load

The total additional heating of the dielectric must not exceed 10 K.

For a frequency point, the additional heating is calculated by the following formula:

$$\Delta T_n = \frac{10 \cdot (V_{Mn})^2}{(V_{Gn})^2} [\text{K}] \quad \text{Formula 1}$$

$V_{Mn}$  = Value measured at frequency  $f_n$

$V_{Gn}$  = Limit for frequency  $f_n$

$\Delta T_n$  = Calculated heating of dielectric for frequency  $f_n$

$f_n$  = Selected frequency

This must be calculated and summed for all occurring  $f_n \geq f_k$ .

$$\Delta T_{\text{ges}} = \sum_{v=1}^m \Delta T_v = \sum_{v=1}^m \frac{10 \cdot (V_{Mv})^2}{(V_{Gv})^2} [\text{K}] \leq 10 \text{ K} \quad \text{Formula 2}$$

$V_{Mv}$  = Value measured at frequency  $f_v$

$V_{Gv}$  = Limit for frequency  $f_v$

$\Delta T_{\text{ges}}$  = Calculated heating of dielectric for all frequencies

$f_v$  = Frequency (with index  $v$  1 .... m)

### 9.4 Assessment of the actual load

The actual load of a filter with higher-frequency voltages can be determined by calculating the temperature rise according to the above procedure on the basis of the measured voltages.

For this purpose, the RMS value of the voltage on the line and load side of the filter must be measured at all occurring frequencies. This is most easily done with a network analyzer that can directly display the various components at the individual frequencies, or by measuring the time function followed by a Fourier transform.

This measurement must be performed for all line/line and line/PE combinations and must be converted to the temperature rise for all these cases. The limits are then read off the applicable diagram (Section 9.7) at the corresponding frequency and inserted in the formula with the measured value. All the temperature values for each case are then summed. If this sum is below 10 K, there is no danger. If it exceeds this value, however, appropriate measures must be taken to reduce the voltage components accordingly.

#### Important:

The voltages must always be measured with incorporated filters under the rated operating conditions. Adjacent equipment must also be taken into account. Measurements without filters are at best useful as a rough guide. Thus resonances resulting from the network circuits (compensation capacitors, series reactors, transformers, leads) can change significantly after installation of a filter.

## General technical information

### 9.5 Example of a permissible load

A filter of type B84143B\*S021 may be loaded with an effective 760 V line-to-line AC voltage (rated voltage 690 V AC + 10%) and maximum permissible harmonics up to the 25<sup>th</sup> order according to DIN EN 50160.

#### 9.5.1 Line/line load

The maximum permissible values for the harmonics according to DIN EN 50160 are used in this example, i.e. a kind of "worst-case" condition for low-voltage networks.

n	V <sub>Mn</sub> V	Frequency Hz	ΔT K
2	8.8	100	0.0040
3	21.9	150	0.0270
4	4.4	200	0.0013
5	26.3	250	0.0582
7	21.9	350	0.0538
9	6.6	450	0.0065
11	15.4	550	0.0470
13	13.2	650	0.0433
17	8.8	850	0.0325
15, 21	2.2	750 ... 1050	0.0043
19, 23, 25	6.6	950 ... 1250	0.0844
6, 8, 10, ... 24	2.2	300 ... 1200	0.0172
Total 2 ... 25			<b>0.3795</b>

A temperature increase of about 0.4 K (permissible value 10 K) is calculated with equation 2: it is caused by all maximum permissible harmonics (DIN EN 50160). It should be noted that the applicable standard stipulates a maximum permissible total harmonic content of 8%. The above example with all maximum values has a THD (Total Harmonic Distortion) of over 11%.

This example shows that EMC filters from EPCOS are safely dimensioned and ensure a sufficient margin to the permissible limits in normal use under typical interference conditions.

Please note that every component has its physical limits, even when it is dimensioned with considerable safety margins, and these may be reached in the event of large higher-frequency voltage components or resonances.

## General technical information

### 9.6 Example of impermissible load

Use of a filter with a rated voltage of 440/250 V at a converter.

In the event of a sub-optimal design (resonances), the converter generates various non-approved higher-frequency voltages during operation.

#### 9.6.1 Line/earth load

n	$V_{Mn}$ (V)	Frequency (Hz)	$\Delta T$ (K)
1	7.34	2350	0.11
2	18.92	2400	0.77
3	29.31	2450	2.03
4	8.13	2500	0.16
5	14.32	4600	0.93
6	56.89	4650	15.98
7	65.33	4700	22.05
8	3.45	4750	0.07
Total			<b>42.10</b>

For example, point 6 of the table results in a  $V_{Gn}$  of **45 V** for 440/250 V on the derating chart (Figure 35).

The calculation using equation 2 results in a temperature rise of **15.98 K** specifically for this frequency.

The summed values ( $\Delta T$ ) yield **42 K**.

#### 9.6.2 Line/line load

n	$V_{Mn}$ (V)	Frequency (Hz)	$\Delta T$ (K)
1	5.23	2350	0.11
2	21.47	2400	2.00
3	27.32	2450	3.24
4	13.39	2500	0.81
5	9.73	4600	0.87
6	73.12	4650	55.64
7	64.83	4700	46.70
8	23.73	4750	6.70
Total			<b>116.06</b>

Here, point 7 of the table results in a  $V_{Gn}$  of **30 V** for 440/250 V on the derating chart (Figure 35).

The calculation using equation 2 results in a temperature rise of **46.7 K** specifically for this frequency.

The summed values ( $\Delta T$ ) yield **116 K**.

### 9.7 General data on voltage derating

The derating charts shown below are typical of many filters and should be seen as a guide for each filter group (2-, 3- and 4-line filters). The values for specific filters may differ from this data. This is because the voltage rating at higher frequencies depends on several parameters:

- The voltage derating of the capacitors used
- The configuration of the capacitors in the filter; e.g. several capacitors in series, in a star or delta circuit
- The rated voltage of the filter (line/line and line/PE)

If the self-heating of the capacitors calculated with the above equations is close to the limit of the permissible values, you should request the specific data for the relevant filter.

#### 9.7.1 2-line filters

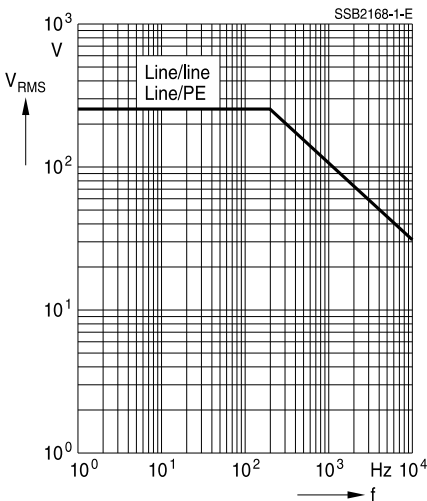

Figure 34 Derating chart for 2-line filter of 250 V



9.7.2 3- and 4-line filters

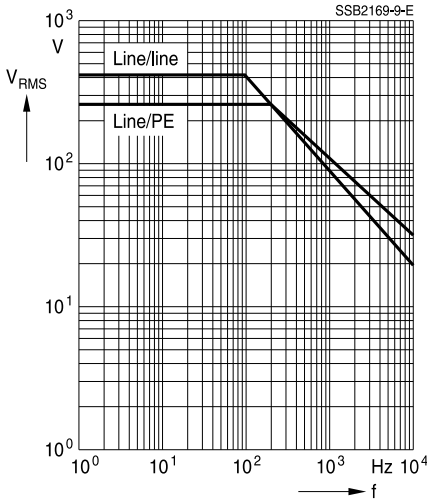

Figure 35 Derating chart for 3- and 4-line filters of 440/250 V

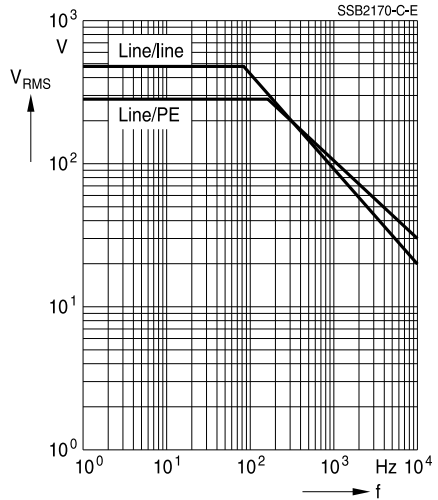

Figure 36 Derating chart for 3- and 4-line filters of 480/275 V

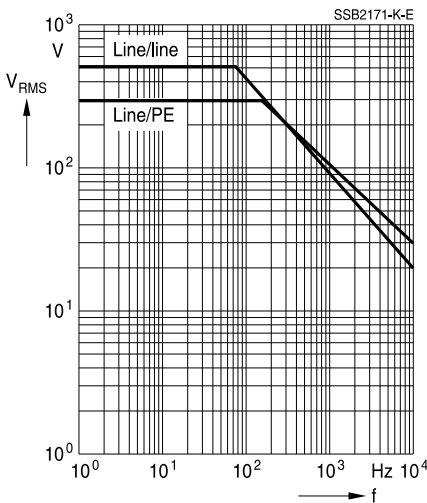

Figure 37 Derating chart for 3- and 4-line filters of 500/290 V

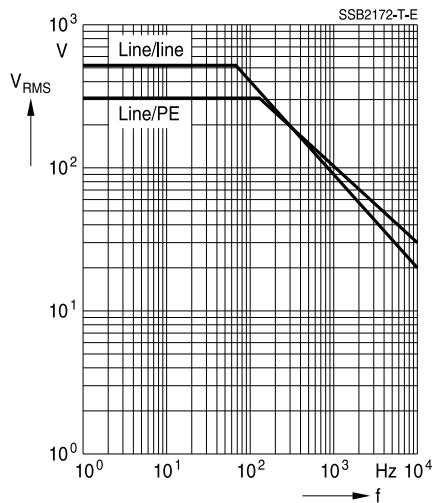

Figure 38 Derating chart for 3- and 4-line filters of 520/300 V

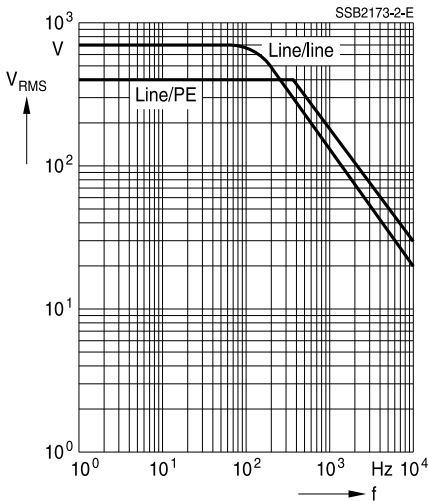

Figure 39 Derating chart for 3- and 4-line filters of 690/400 V

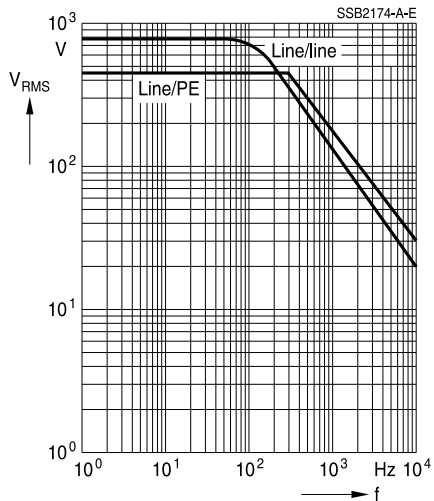

Figure 40 Derating chart for 3- and 4-line filters of 760/440 V

### 9.7.3 Dangers of filter overload

Experience has shown that regular low-voltage networks contain no critical higher-frequency components. Capacitor overload and hence any dangers can thus be excluded. The maximum permissible values for the 2nd to 25th harmonics of the line frequency referred to in the DIN EN 50160 standard may be seen as a kind of worst case.

- However, it should be ensured that no resonant circuits are produced, for instance due to un-matched compensation capacitors, transformers, capacitive components of the filters or lines.
- In particular, care must be taken when using frequency converters that any possible resonant frequencies do not coincide with the clock frequency of the converter or its harmonics.
- If the permissible limits for the higher-frequency voltage components at the filter are exceeded, this could lead to damage or destruction of the filters.

## General technical information

An impermissible overload leads to strong heating of the dielectrics in the capacitors, which can cause voltage breakdowns and short circuits in the capacitors. Such short circuits can as a rule produce very high secondary currents which are fed by the energy stored in the capacitors or directly from the connected power supply. In both cases, these power sources have an extremely low internal resistance, which leads to high secondary currents (several kA).

These secondary currents can only be turned off when the back-up fuse is triggered, a process which never provides any protection for the filter and the capacitors it contains.

Depending on the ambient conditions (e.g. installation in equipment or switching cabinet) and the filter design, consequential damage can also occur to the filter itself and its surroundings. See also chapter "Cautions and warnings".

10 Current derating

10.1 Current derating at ambient temperatures exceeding the rated temperature

⚠ Filters from EPCOS are designed for continuous operation at their rated voltage and frequency. They are designed to be operated at their full rated current up to the specified rated temperature (typically 40 °C). When operated at higher ambient temperatures  $T_A$  than the specified rated temperature, the maximum continuous operating current is obtained by multiplying the rated current by the corresponding derating factor (Figures 41 and 42). Non-observance of the current derating may lead to overheating and thus to the risk of fire.

$$I_{\max(T_A)} = I_R \cdot \left( \frac{I}{I_R} \right)$$

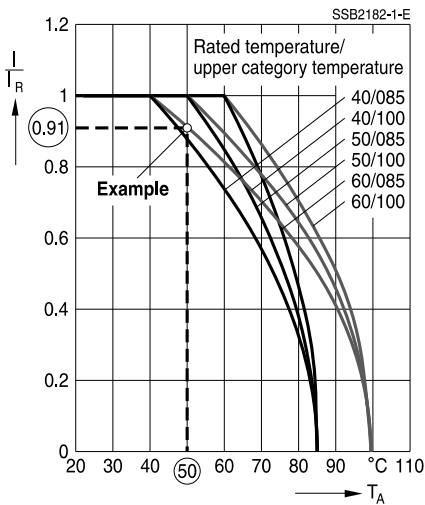

Figure 41  
Current rating  $I/I_R$  as a function of the ambient temperature  $T_A$  for EMC filters

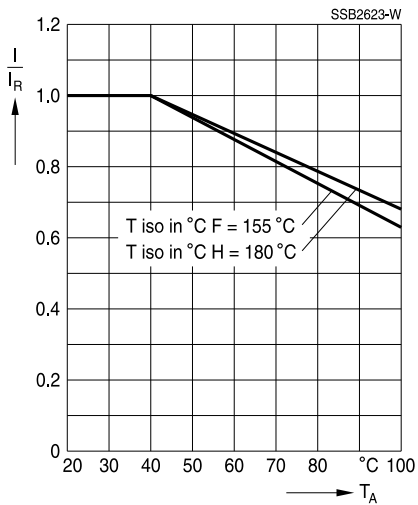

Figure 42  
Current rating  $I/I_R$  as a function of the ambient temperature  $T_A$  for chokes

## General technical information

The following curves are valid for the specified conditions:

Curve	Rated temperature $T_R$	Upper category temperature $T_{max}^{14)}$
40/085	40 °C	85 °C
40/100	40 °C	100 °C
50/085	50 °C	85 °C
50/100	50 °C	100 °C
60/085	60 °C	85 °C
60/100	60 °C	100 °C

### Application of the current derating charts

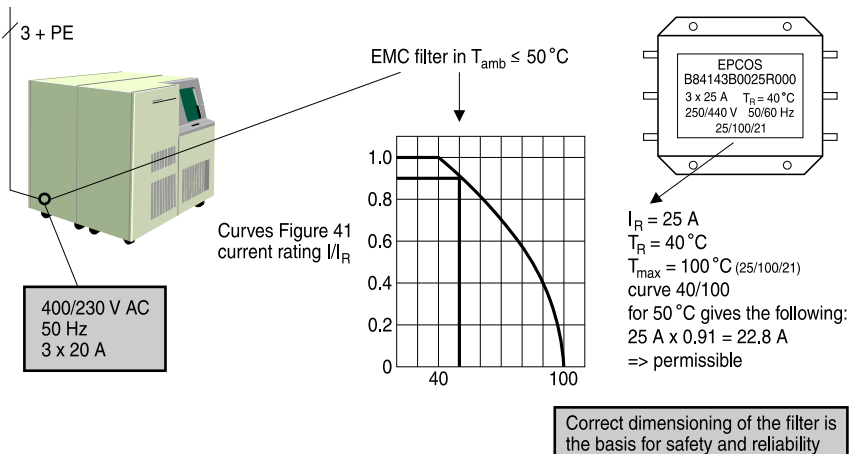

SSB2624-5-E

Figure 43 Application of the current derating charts

#### Example:

Given the following:

- Filter B84143B0320S020 ( $I_R = 320\text{ A}$ )
- Control cabinet with max. internal temperature of 50 °C
- Max. continuous current (RMS) at the converter input: 280 A

Solution:

From the data sheet of the filter B84143B0320S020:

- 320 A rated current at a
- rated temperature of 40 °C
- and an upper category temperature of 100 °C (climate category 25/100/21)

14) Mid-range number group in the climate category specification (e.g. 25/085/21; 25/100/21) see Sections 3.3.1 and 3.3.4.

## General technical information

From the current derating charts:

- Select applicable curve 40/100
- At an ambient temperature of 50 °C, read off the corresponding current rating  $I/I_R = 0.91$
- $320 \text{ A} \times 0.91 = 291 \text{ A}$  (maximum permissible continuous current at 50 °C)
- $291 \text{ A} > 280 \text{ A}$

In this specific example, the filter can be used with a maximum continuous current of 280 A and is thus correctly dimensioned.

### 10.2 Current derating of 4-line filters with neutral line load

In 4-line filters (3 line conductors + 1 neutral conductor), the specified rated current refers to a three-phase load with a total current flowing through the neutral conductor close to zero. Specifically for applications with clocked power supplies such as computers and electronic ballasts, significant loading of the neutral conductor is to be expected, which in the worst case can exceed the magnitude of the phase currents. Here, the rated current of the 4-line filter should be greater than the expected operating current. For an equal current flowing through the neutral and line conductors, a derating factor of  $I/I_R = 0.85$  is obtained.

*Example:*

Given that:

- $I_{L1} = I_{L2} = I_{L3} = I_N = 36 \text{ A}$
- Filter B84144A0050R000 ( $I_R = 50 \text{ A}$ )

$I_{LX}$  = Current through conductors L1... L3

$I_N$  = Current through neutral conductor

Solution:

Permissible load (3-phase + neutral):

$$I = 0.85 \cdot I_R = 0.85 \cdot 50 \text{ A} = 42 \text{ A}$$

## General technical information

### 11 Current and voltage derating as a function of the altitude

If filters or chokes are set up at altitudes > 2000 m above NHN<sup>15)</sup>, the physical conditions mean that the heat dissipation of the filters and chokes can no longer be assured to its full extent. When these components are used at altitudes > 2000 m, therefore, the following derating factors must be considered. Values between the table entries should be interpolated.

#### 11.1 Current derating as function of altitude

Installation height above NHN <sup>15)</sup> m	Derating factor
0 ... 2000	1.000
2250	0.981
2500	0.963
2750	0.944
3000	0.925
3250	0.906
3500	0.888
3750	0.869
4000	0.850

Example calculation:

When using a filter or choke with a rated current of 600 A at an altitude of 2500 m above NHN<sup>15)</sup>, the maximum continuous current is 577 A;  $600 \text{ A} \times 0.963 = 577 \text{ A}$ .

#### 11.2 Voltage derating as function of altitude

Installation height above NHN <sup>15)</sup> m	Voltage derating factor
0 ... 2000	1.000
2250	0.970
2500	0.940
2750	0.910
3000	0.880
3250	0.850
3500	0.820
3750	0.790
4000	0.760

Example calculation:

When using a filter or choke with a rated voltage of 760 V at an altitude of 2500 m above NHN<sup>15)</sup>, the maximum effective operating voltage is 714 V;  $760 \text{ V} \times 0.94 = 714 \text{ V}$ .

<sup>15)</sup> m about NHN = standard elevation zero; since 1993, (NHN) has been the new altitude reference level in the DHHN92 system

## General technical information

### 12 Mechanical tests

The most diverse oscillation, shock and impact tests must be satisfied depending on the application and mounting position.

#### 12.1 Passive filters for suppressing electromagnetic interference

Framework specification EN 60939 and the EN standard 60068-2-\* (IEC 60068-2-\*) stipulate the following test conditions:

##### a) Vibrations (Fc according to EN 60068-2-6)

Vibration stressing must be applied with a sliding frequency scale. The following preferred severity levels are specified:

0.75 mm displacement or 98 m/s<sup>2</sup>.

The lower amplitude applies in one of the following frequency ranges:

10 Hz to 55 Hz

10 Hz to 500 Hz

10 Hz to 2000 Hz

The preferred duration is 6 hours, distributed evenly over the vibration axes.

The design specification must define the severity level and type of mounting.

##### b) Shocks (Ea test according to EN 60068-2-27; IEC 60068-2-27)

The design specification must define the severity level and type of mounting. The following severity levels are preferred:

Pulse shape: half-sinusoidal

Peak acceleration m/s <sup>2</sup> (g)	Associated pulse duration ms
49 ( 5)	30
294 ( 30)	18
490 ( 50)	11
981 (100)	6

##### c) Continuous shocks (Eb test according to EN 60068-2-29; IEC 60068-2-29)

The design specification must define the severity level and type of mounting. The following severity levels are preferred:

Total number of shocks: 1000 or 4000

Acceleration m/s <sup>2</sup> (g)	Associated pulse duration ms
390 ( 40)	6
98 ( 10)	16

The values specified above can only be observed with fully potted and as a rule small filters (< 1 kg).



## General technical information

### 12.2 Filters for converters or unpotted filters

As these are usually very complex filters with mechanical resonance capability, the general specifications according to EN 60068-2-\* (IEC 60068-2-\*) are selected, but significantly lower severity levels are applied than those stipulated by EN 60939. (Resonance increases of up to a factor of 7 have been measured in the range of responses.)

- a) Vibration                    Fc test according to EN 60068-2-6 (IEC 60068-2-6):  
    Packaged or unpackaged  
    As a rule max. 2 g,  
    Frequency range 10 ... 500 Hz
- b) Shocks                        Ea test according according to EN 60068-2-27 (IEC 60068-2-27):  
    Acceleration                max. 5 g  
    Pulse duration              30 ms  
    6 directions                18 shocks in total

The following tests are additionally applied in special cases:

- c) Drop                            Test according to EN 60068-2-31:  
    Unpacked 100 mm height,  
    Once around each bottom edge.
- d) Topple                        Test according to EN 60068-2-31:  
    Once around each bottom edge.
- e) Free fall                        Test according to EN 60068-2-32:  
    Unpacked 100 mm,  
    Transport packaged 500 mm,  
    Twice on the base area.

### 12.3 Installation of power and communications-line filters in special protective rooms

The conditions stipulated by the German Federal Ministry for Regional Planning, Building and Urban Development apply in this case. The most important parameters are the rule classes (RK).

A shock safety class is defined by the shock polygon ( $V_{max}$ ,  $a_{max}$ ,  $s_{max}$ ,  $r_{max}$ ). The safety class parameters also define the minimum values of the shock test parameters as well as the parameters for the calculated confirmation of strength and deformation.

The parameter combinations listed in the following table are defined as the rule classes for protected rooms.

Rule class	Main characteristics		Secondary characteristics	
	$V_{max}$	$a_{max}$	$s_{max}$	$r_{max}$
Rk 0.63/ 6.3	0.63 m/s	6.3 g	= 10 cm	= 1.5 g / ms
Rk 1.0 /10	1.0 m/s	10 g	= 16 cm	= 2.5 g / ms
Rk 1.6 /16	1.6 m/s	16 g	= 25 cm	= 4.0 g / ms
Rk 2.5 /25	2.5 m/s	25 g	= 40 cm	= 6.3 g / ms
Rk 4.0 /40	4.0 m/s	40 g	= 63 cm	= 10 g / ms

RK 1.6/16 is normally selected for mounting filters on ceilings and walls.

## 12.4 Military applications

The requirements of the German Federal Office for Defense Technology and Procurement (BWB) largely apply to military applications. The test center body must have the authorization to carry out the tests.

The tests are defined by the BWB on the basis of the mounting position. The structure and presentation of the test report are prescribed.

Excerpt from the requirements for the shaking test:

S <sub>0</sub> (mm)	a <sub>0</sub> m/s <sup>2</sup>	f 1/s
0.63	4	2 ... 31.5
1.0	6.3	2 ... 40
1.6	10	2 ... 50
2.5	16	2 ... 63

Shock safety classes A to C, as well as set-up areas I ...III are defined for the shock tests. The shocks may be triangular, rectangular or sinusoidal. In some cases, the VG standards VG 95332, VG 88561 or MIL specification MIL 810 are also applied. Additional shock tests are added in these cases.

## 13 Labeling the filters and chokes

The filter and chokes from EPCOS are usually labeled as follows:

- Manufacturer's name or logo
- Ordering code
- Assigned test
- Rated voltage, rated frequency
- Rated current, rated temperature
- Climate category
- Date of manufacture (encoded)

**General:               YYWWD**

Example:

13285           => 13 = Year 2013  
                       28 = Week 28  
                       5 = 5<sup>th</sup> day of the week = Friday  
 = 12 July 2013

**SIFI series (old) as well as feedthrough filters and capacitors: MM.YY**

Example:

07.13           => 07 = Month July  
                       13 = Year 2013  
 = July 2013

Different labels are available upon customer request.

## General technical information

### 14 Packaging labeling/barcode

The packaging cartons for the filters and chokes are marked with a packaging label as standard. In addition, the information is displayed in bar code 39.

This enables secure, fast and error-free identification up to the customer. Customer-specific labels are available upon request.

The packaging label contains the following information:

- Manufacturer
- Name of the filter or choke
- Note on RoHS compatibility
- [1P]: Product ordering number
- [9K]: Purchase order number
- [D]: Date of manufacture YYMMDD [Y = year; M = month; D = Day]
- [T]: Batch number
- [Q]: Quantity
- Country of manufacture



Figure 44 Example of a label on the packaging carton